

# MURPHY REBEL Control Column

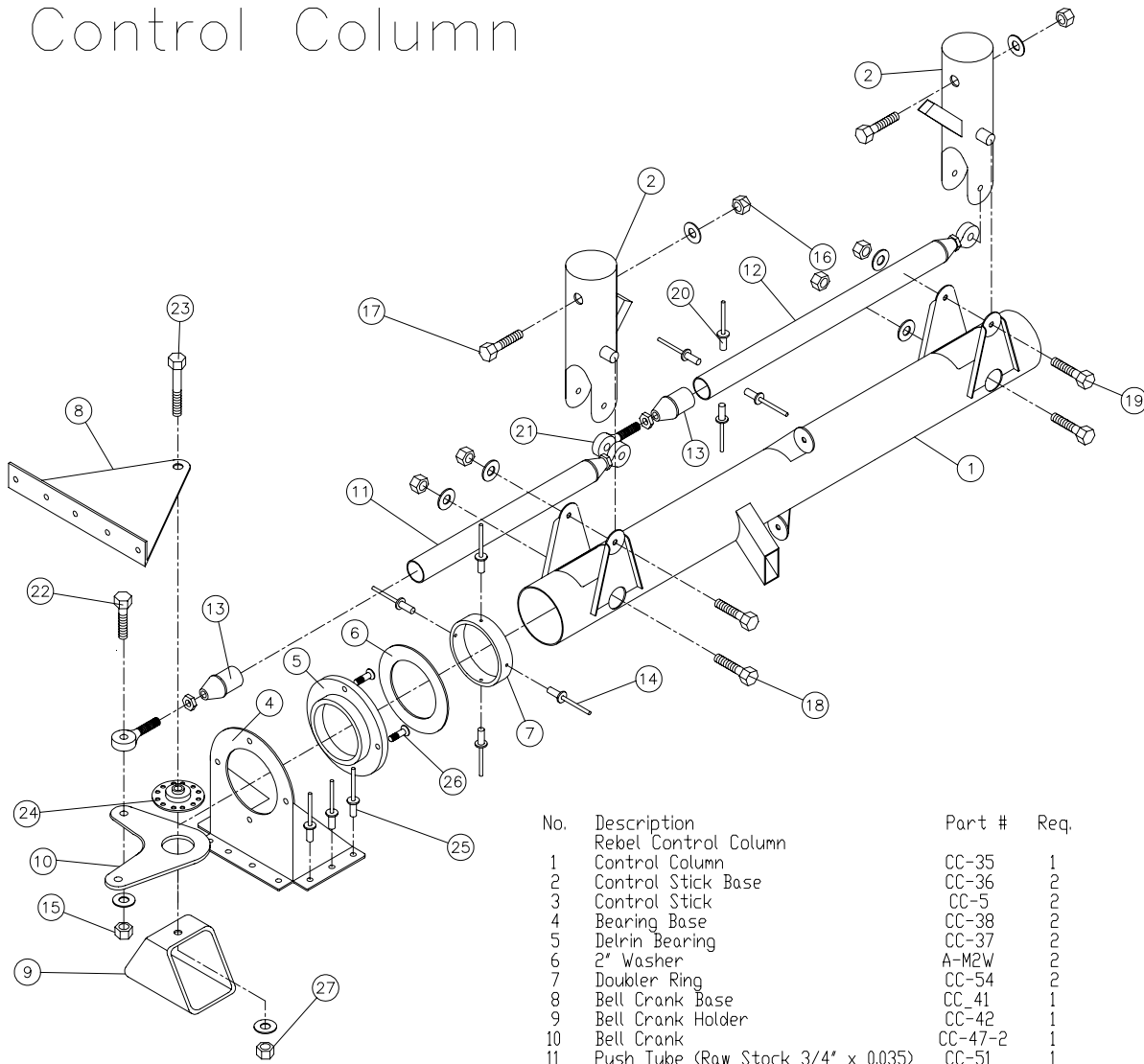

No.	Description	Part #	Req.
	Rebel Control Column		
1	Control Column	CC-35	1
2	Control Stick Base	CC-36	2
3	Control Stick	CC-5	2
4	Bearing Base	CC-38	2
5	Delrin Bearing	CC-37	2
6	2" Washer	A-M2W	2
7	Doubler Ring	CC-54	2
8	Bell Crank Base	CC_41	1
9	Bell Crank Holder	CC-42	1
10	Bell Crank	CC-47-2	1
11	Push Tube (Raw Stock 3/4" x 0.035)	CC-51	1
12	Push Tube (Raw Stock 3/4" x 0.035)	CC-51	1
13	Tube End Plug	CC-29	4
14	3/16" x 1/8" SS rivets	RR-5604	8
15	1/4" Fiber nuts	AN365-428	5
16	3/16" Fiber Nuts	AN365-1032	2
17	3/16" Bolt	AN3-14A	2
18	1/4" Bolt	AN4-13A	2
19	1/4" Bolt	AN4-25A	2
20	1/8" x 1/8" SS rivets	RR-5404	16
21	Male Rod End Bearing	HM4M	4
22	1/4" Bolt	AN4	1
23	5/16" Bolt	AN5-16A	1
24	Bell Crank Bearing	MI-25	1
25	3/16" x 1/4" Avex Rivets	RV-1613	28
26	Screw	AN509-1032R	8
27	5/16" Fiber Nuts	AN365-524	1

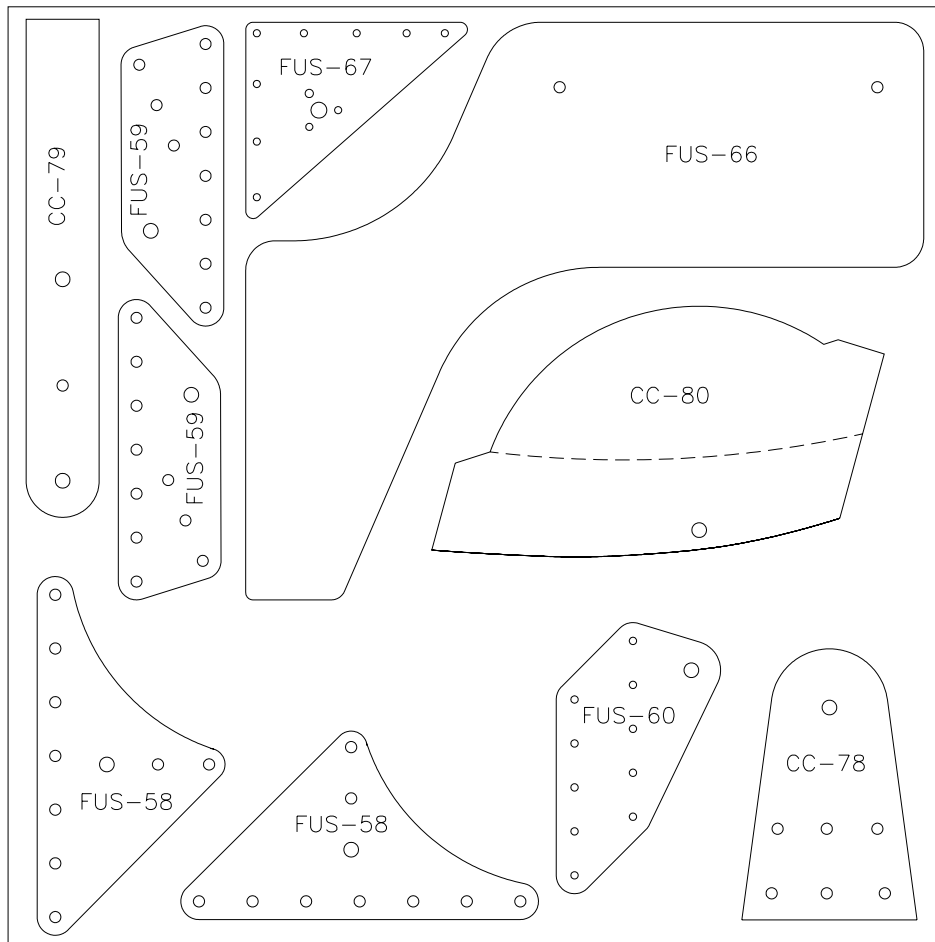

FUS-57  
2024-T3 16"x16"x.125

[OCW0528]

20.1 Brake Pedal Install

1) Slide the left brake pedal (BP-4) on the pedal assembly (RP-14). The lugs on the pedal and brake should face to the front of the airplane. Figure 20.1.1.

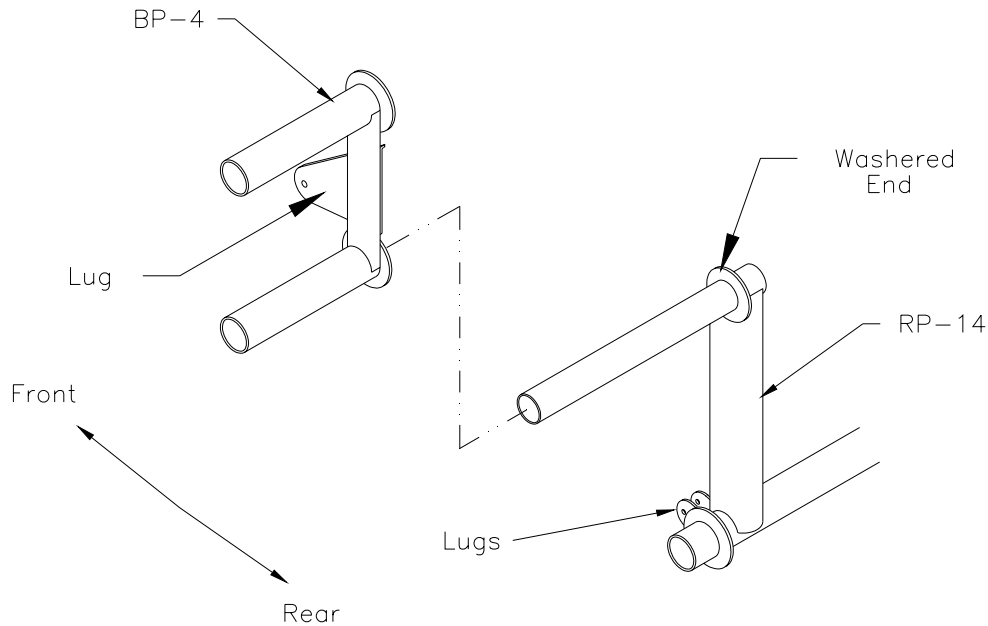

Figure 20.1.1

2) Assemble the brake slave cylinder with the threaded fork on the end. Bolt the fork to the brake pedal lug with an AN3-7 bolt and castle nut (AN310-3). Drill a 3/16" hole through the bottom lugs and brake slave cylinder. Figure 20.1.2

**NOTE:** Left oil fittings should exit toward the passenger side. The right oil fitting should exit forward. It may be necessary to cut off a couple of threads from the brake cylinder shaft to allow clearance upon assembly.

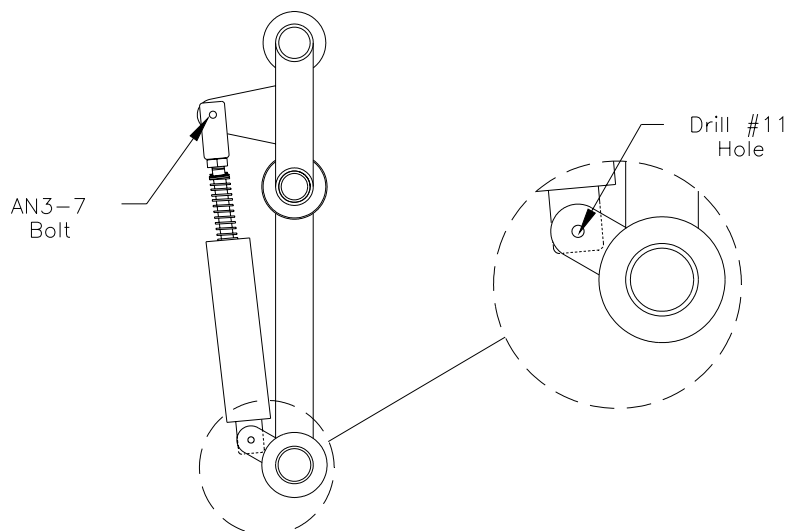

Figure 20.1.2

## 20.0 CONTROL INSTALLATION

3/2/2006

3) Slide a washer (M18-L ) onto the Rudder Pedal against the Brake Pedal. Drill a #30 hole through the rudder pedal and install a cotter pin (MS24665-357). Figure 20.1.3.

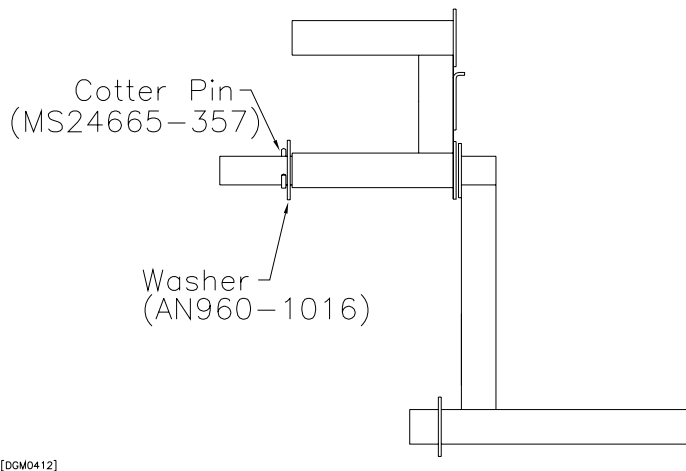

Figure 20.1.3

4) Repeat steps for the other pedal assembly.

5) Drill #11 holes 3/8" in from the end ends of the rudder pedals. Insert eyebolts (AN42B-10A) and attach with fiber nuts (AN365-1032). Ensure that the eyebolts are approximately 90° to the rudder pedals. Figure 20.1.4.

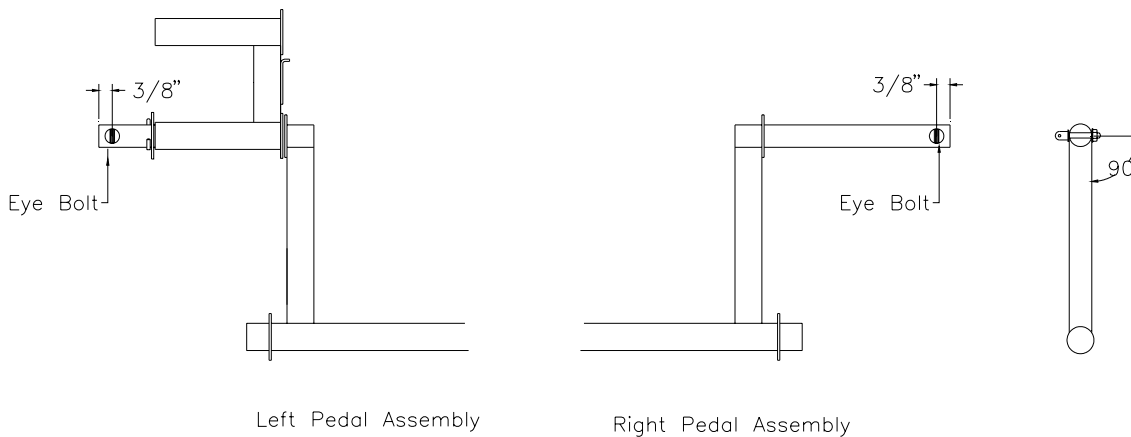

Figure 20.1.4

## 20.2 Rudder Pedal Install

- 1) On the cabin front floor, measure the distance from the firewall to the bottom carrythrough.
- 2) Cut a Floor Stiffener from 5/8" x 5/8" square tubing (FUS-14) to the measurement you just found.
- 3) Position the 5/8" tube on the floor center and back drill #30 holes through the floor into the tube at 1" spacing. Figure 20.2.1.
- 4) Remove, debur and chromate mating surfaces. Rivet to the floor with 1/8" (RV-1410) rivets.

**20.0 CONTROL INSTALLATION**

3/2/2006

- 5) Slide two bearing blocks (RP-13) onto each rudder pedal assembly. Position both pedal assemblies on the floor as in figure 20.2.1. Position pedals so that they are behind the engine mount brackets. Ensure that the rudder pedals clear the engine mounts.
- 6) Drill back through bearing blocks and into the floor with a #11 drill.

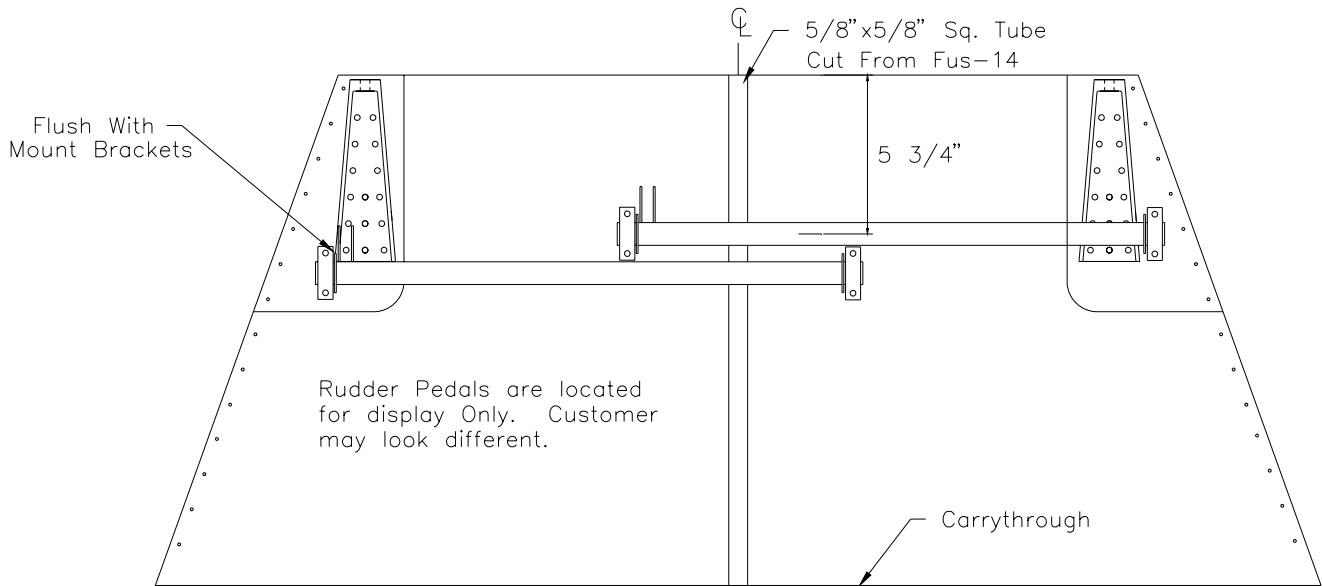

Figure 20.2.1

- 7) Make two doublers from .032 raw stock (W-143). Figure 20.2.2.

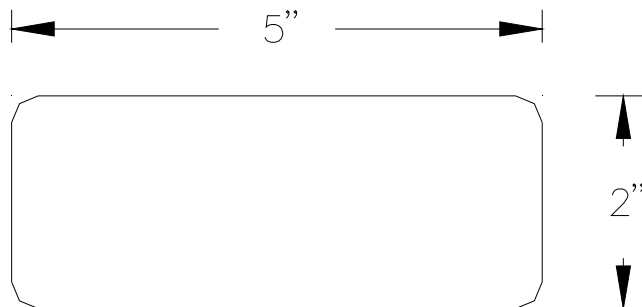

Figure 20.2.2

- 8) Center doubler over the bearing block at the center of the floor. Drill #30 holes around the outer edge of the doubler and cleco. Figure 20.2.3.

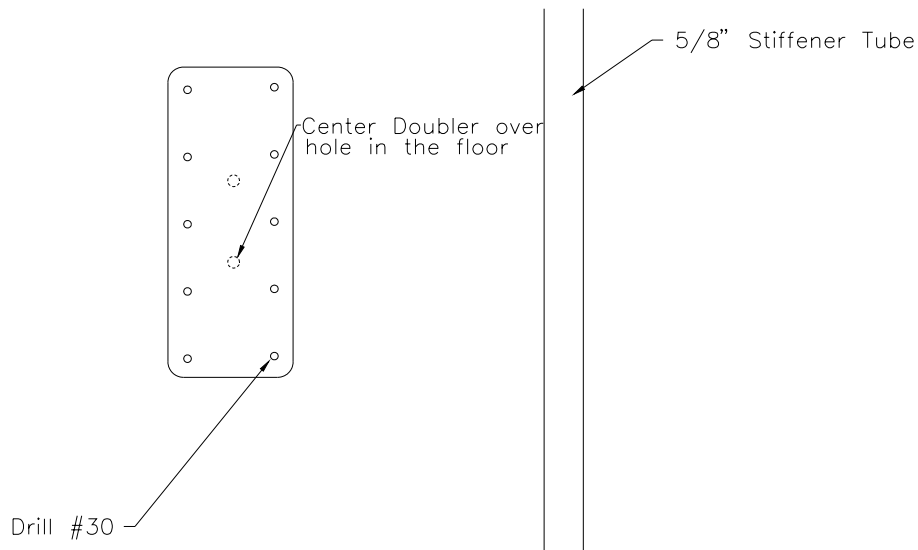

Figure 20.2.3

9) Back drill doublers for the bearing blocks. Figure 20.2.4.

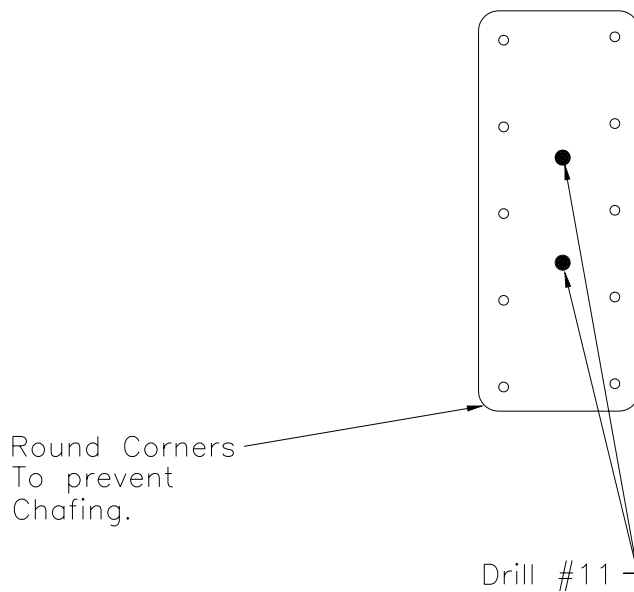

Figure 20.2.4

10) Remove doublers. Debur floor and doublers.

11) Chromate and rivet doublers to the floor using 1/8" (RV-1410) rivets.

12) Attach rudder pedal assemblies and bearing blocks to the floor with AN3-22A bolts, AN365-1032 fiber nuts and AN960-10 washers.

13) Drill a #40 hole part way through each outside tube of the rudder pedals. Drill a #40 hole into the side of the Bottom Engine Mount Bracket (FUS-85-1). Attach Rudder Pedal Return Springs (311-606). Figure 20.2.5.

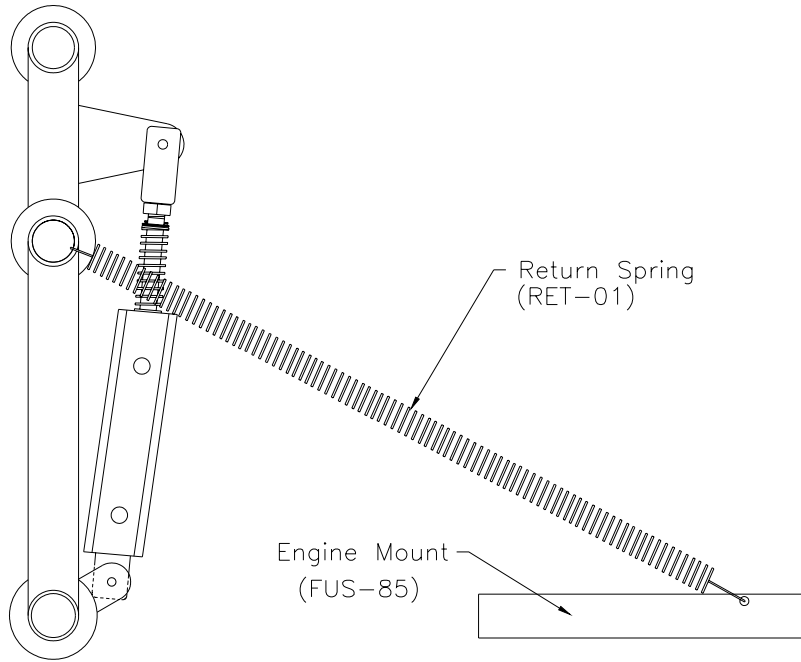

Figure 20.2.5

### 20.3 Control Column Install

- 1) Bolt Delrin Bearing (CC-37) inside the bearing plates (CC-38) similar to what was done in the wing assembly.
- 2) Install the control sticks (CC-5) in the control stick bases (CC-36). Make one left and one right stick.

Figure 20.3.1.

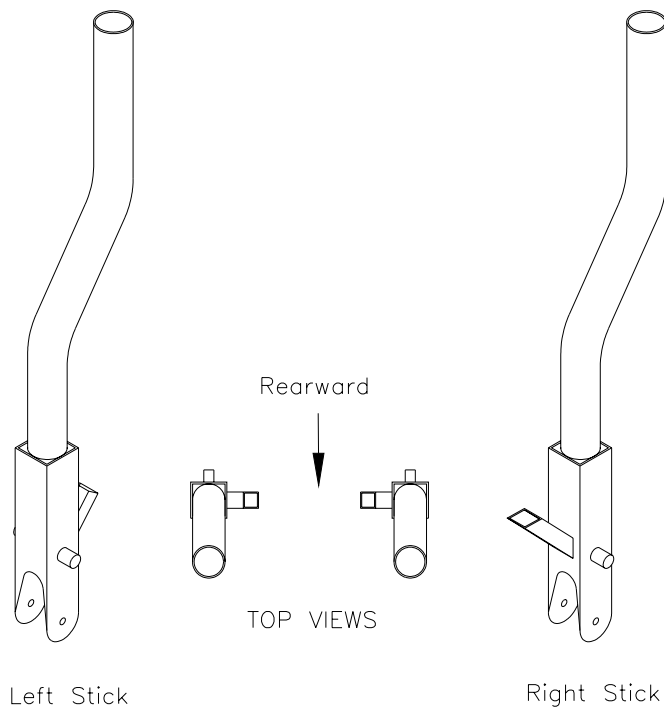

Figure 20.3.1

**20.0 CONTROL INSTALLATION**

3/2/2006

3) Drill a #11 hole through the control stick base and control stick. Bolt together with AN3-13A bolts, AN960-10 washers, AN365-1032 fiber nuts. Figure 20.3.2.

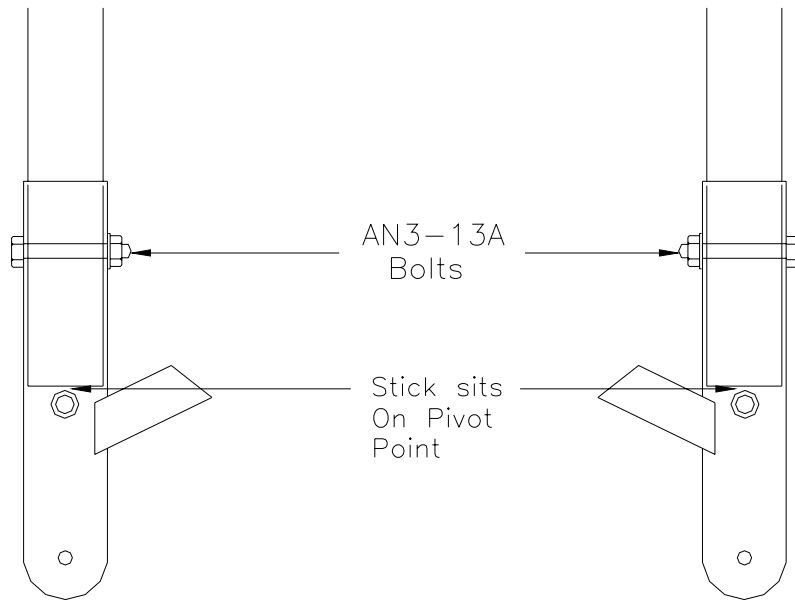

Figure 20.3.2

4) Drill or grind out two 3/4" holes through the control column (CC-35). Figure 20.3.3.

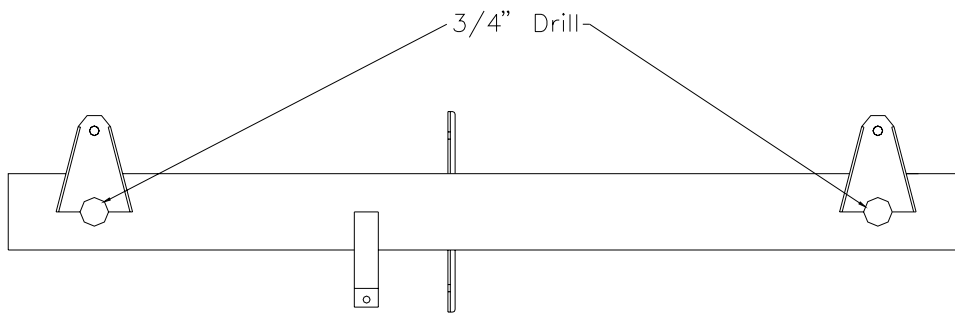

Figure 20.3.3

5) Attach the Control Sticks to the Torque Tube (CC-35) with AN4-25 bolts, AN960-416 washers, AN310-4 castle nuts and MS24665-132 cotter pins. Figure 20.3.4.

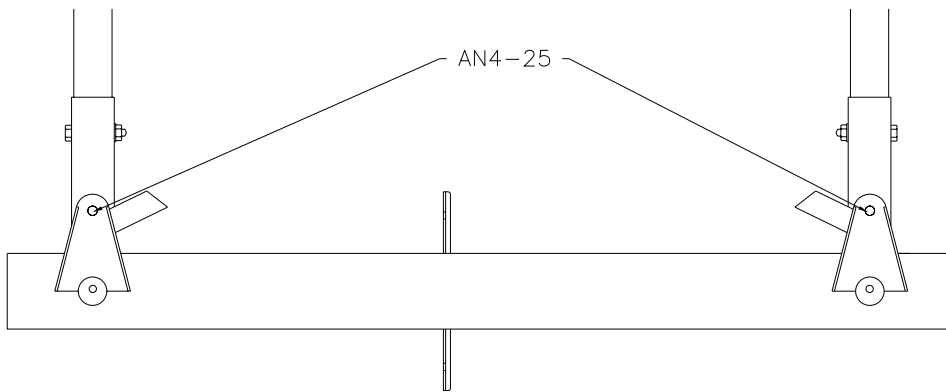

Figure 20.3.4

6) Make the Control Stick Connector Tube (CC-39) from 3/4" x .035" tube (CC-51). Figure 20.3.5.

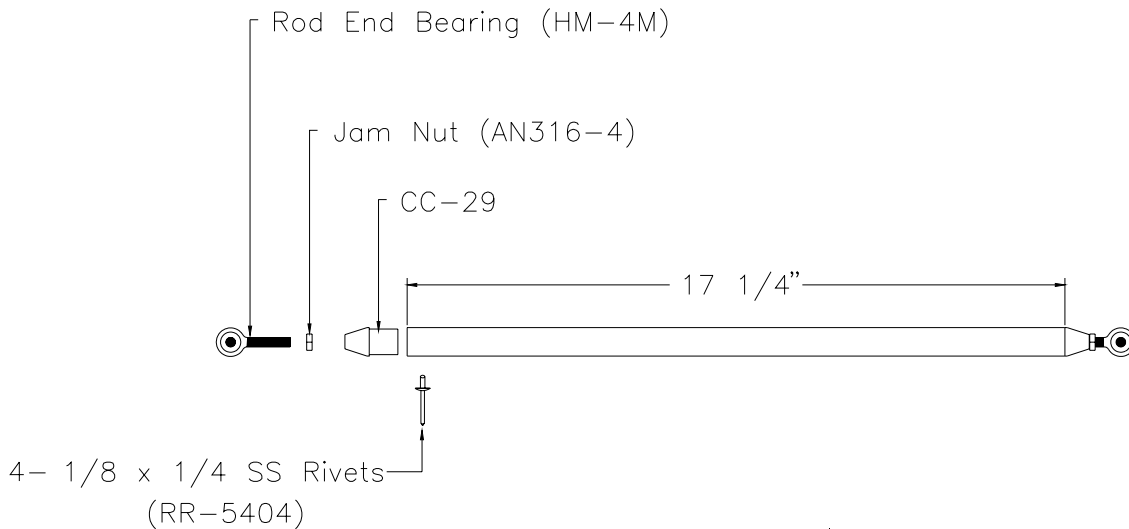

Figure 20.3.5

7) Adjust the connector tube to fit between the Control Sticks. Make sure the sticks are vertical. Figure 20.3.6.

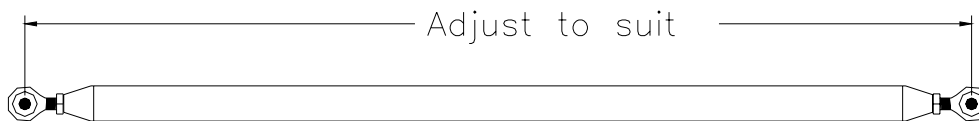

Figure 20.3.6

8) Attach one end of the connector tube to the passenger stick assembly. Use AN960-416 washers to take up the excess space. Figure 20.3.7.

**IMPORTANT:** Use a washer under the head and the nut and tighten until the sides of the Stick Base angle in slightly. Otherwise the end of the bolt can stick out too far and catch on the sides of the control column. Be sure to test for smooth operation without interference. **NOTE:** you will be adding another rod end for CC-40 later. Do not final install.

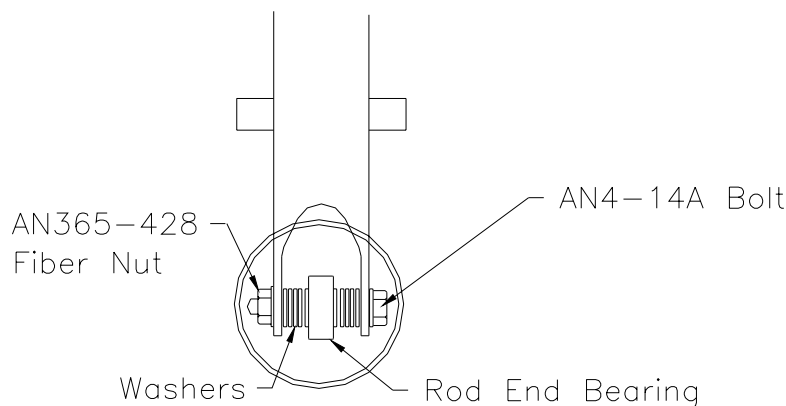

Figure 20.3.7

9) Slide the doubler rings (CC-54) onto the Control Torque Tube (CC-35). Drill four #11 holes through each doubler ring. Figure 20.3.8.

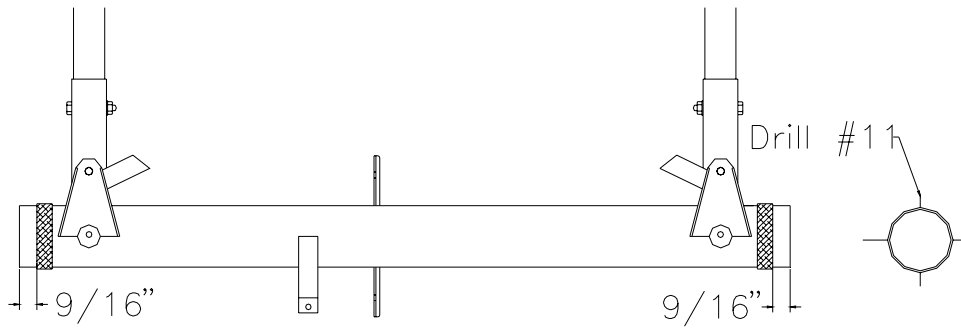

Figure 20.3.8

10) Remove the doubler rings. Debur. Rivet the rings on with 3/16" S.S. rivets (RR-5604).

11) Slide 2" washers (A-M2W) on the torque tube up against the doubler rings.

**NOTE:** .040 re-enforcing plates will need to be made to attach Control Bases to cage on the cut carrythrough versions.

12) Place a bearing base assembly on each end of the control torque tube assembly. Figure 20.3.9.

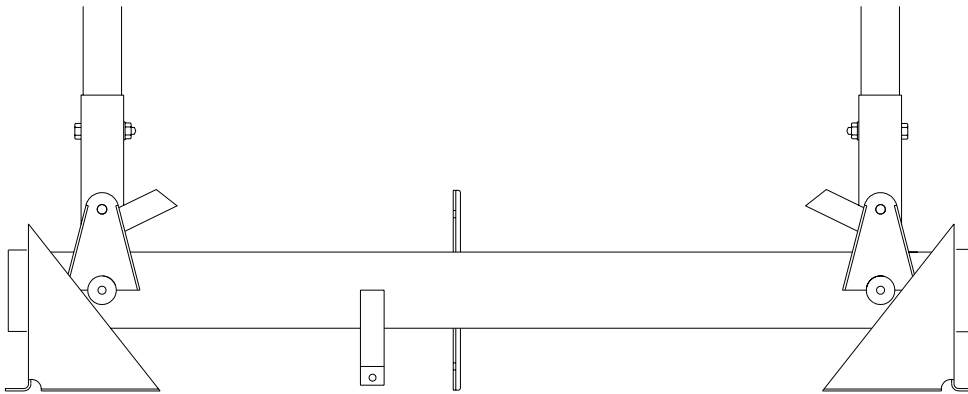

Figure 20.3.9

13) Center assembly on the Carrythroughs (FUS-5). Figure 20.3.10.

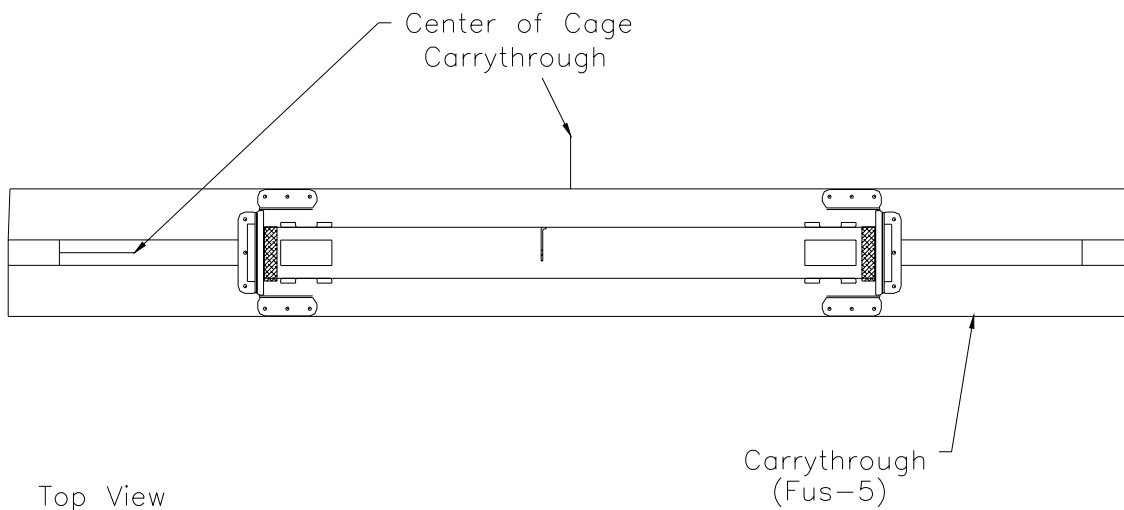

Figure 20.3.10

14) Drill #11 holes and cleco the bearing bases to the floor. Figure 20.3.11.

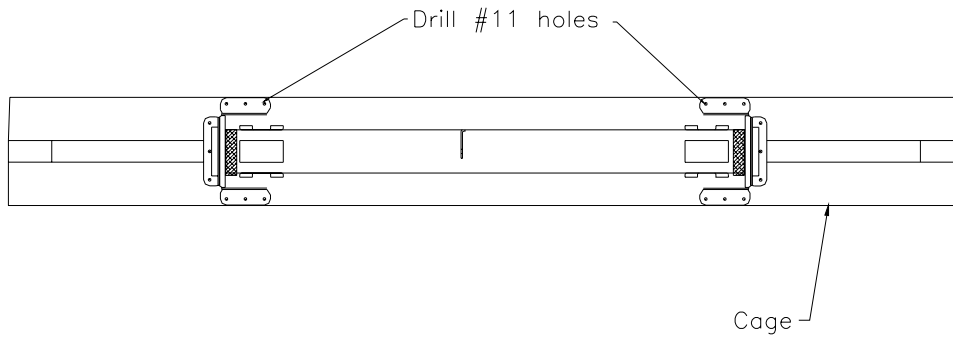

Figure 20.3.11

15) Locate and mark the position of the elevator stop (CC-67). Figure 20.3.12.

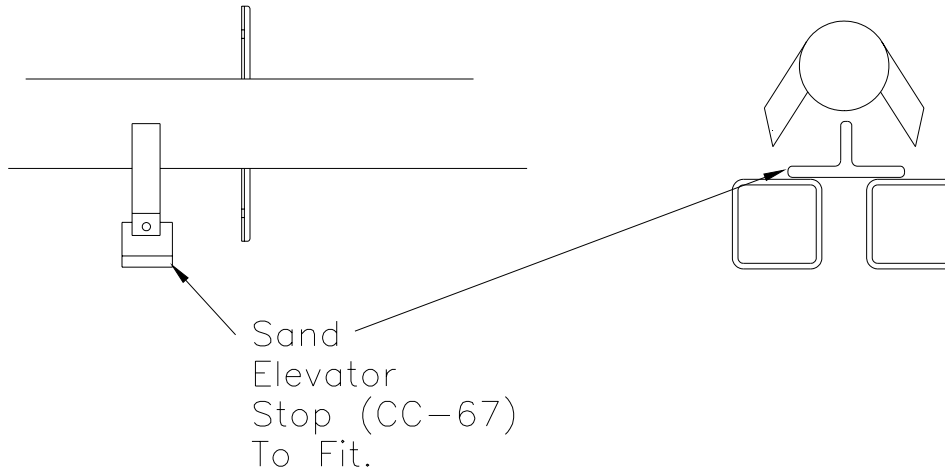

Figure 20.3.12

16) Remove control column assembly.

17) Drill four #11 holes through the elevator stop (CC-67) into the carrythroughs (FUS-5). Figure 20.3.13.

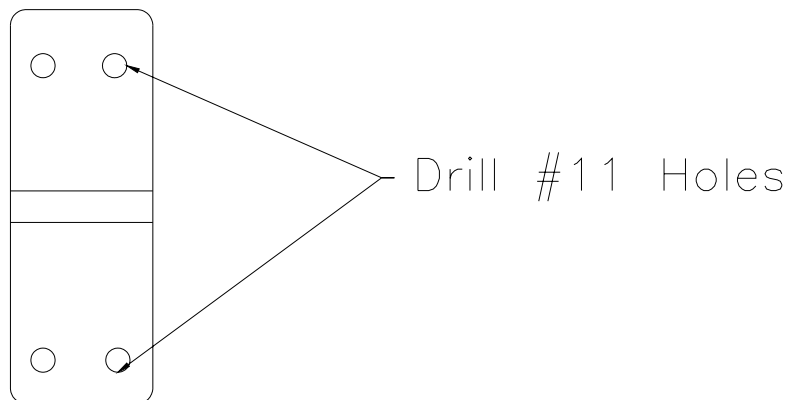

Figure 20.3.13

18) Deburr the elevator stop. Chromate mating surfaces and rivet with 3/16" (RV-1621) rivets.

19) Deburr and chromate mating surface of the bearing bases. Rivet the control column assembly to cage with 3/16" (RV-1613) rivets. Install AN3-6A bolts with washers under the heads into the stop tubes on the column for both elevator and flapperons. Adjust with washers so bolt head contacts stop or torque tube to achieve desired control deflections.

20.4 Bell Crank Install

1) Position the bell crank holder (CC-42) as per figure 20.4.1.

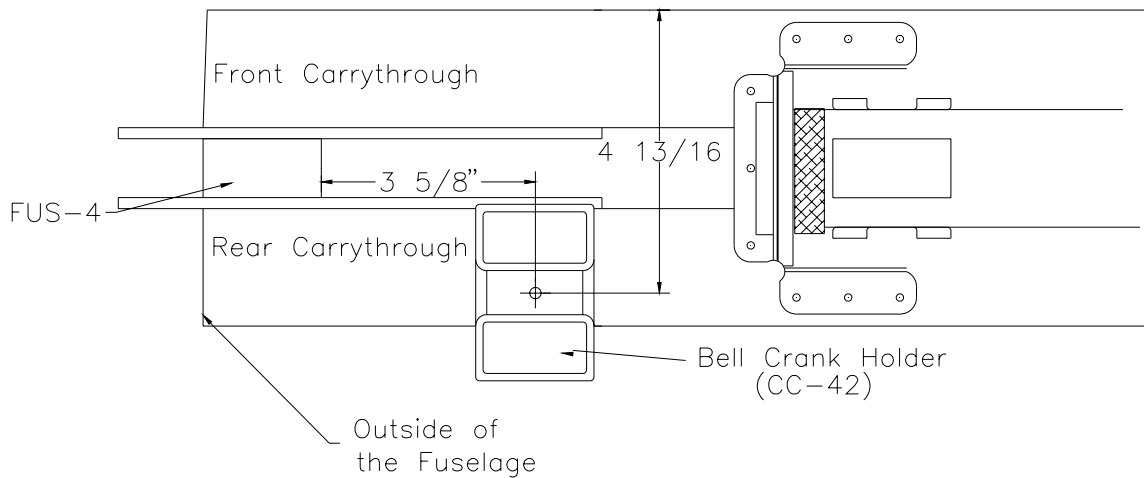

Figure 20.4.1

2) Drill six #30 holes through the bell crank holder into the floor. Figure 20.4.2.

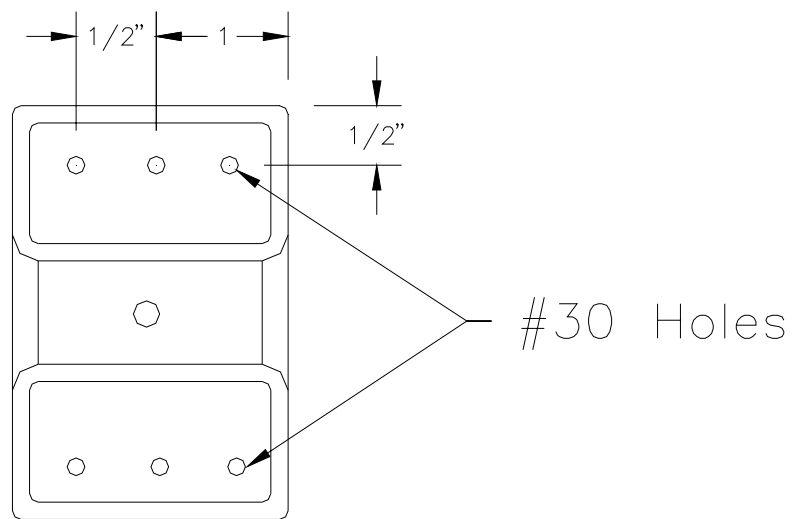

Figure 20.4.2

3) Debur all holes.

4) Rivet the bell crank holder to the floor with 1/8" (RR-5406) S.S. rivets.

5) Use the Bell Crank Bearing (MI-25) as a drill guide to drill twelve #30 holes into the mixer (CC-47-2).  
Figure 20.4.3.

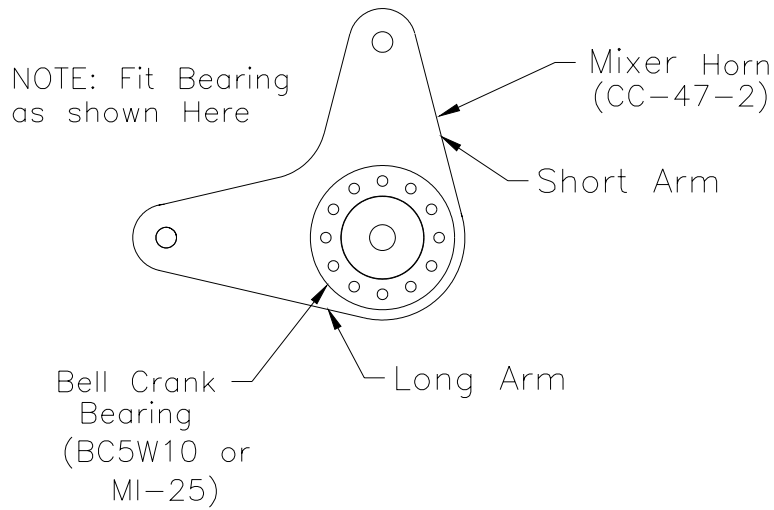

Figure 20.4.3

6) Debur mixer.

7) Attach bell crank bearing to the mixer with 1/8" (RR-5404) S.S. rivets. Insert rivets in a one up, one down pattern. Figure 20.4.4.

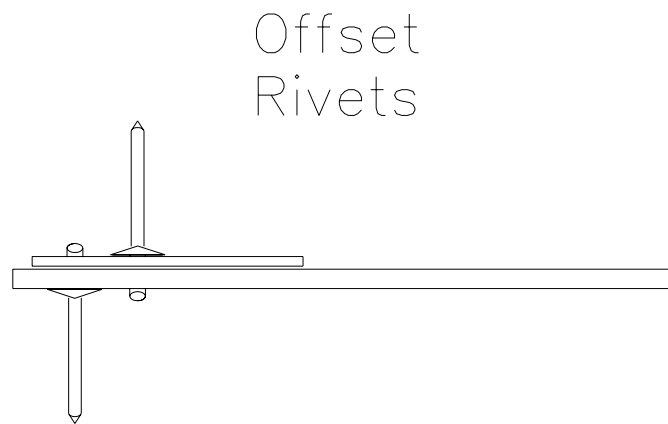

Figure 20.4.4

8) Drill out the hole in a W-62-1 to 5/16". Cut the W-62-1 in half so that you have two equal parts of approximately 3/8" long. Figure 20.4.5.

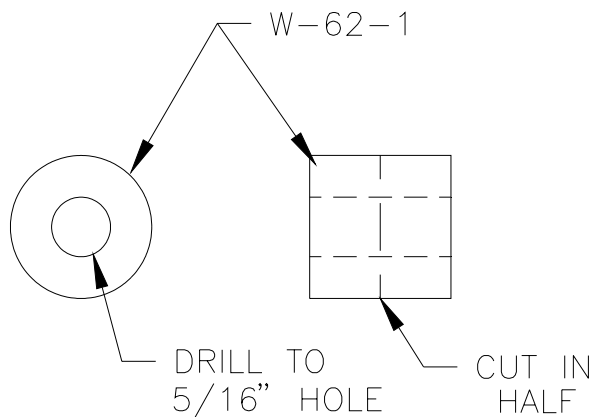

Figure 20.4.5

**20.0 CONTROL INSTALLATION**

3/2/2006

9) Place the spacers and bellcrank on top of the bell crank holder. Position the Bell Crank Brace (CC-41) centered on the top spacer. Layout and drill 7 #30 holes through the Bell Crank Brace into the fuselage.

Figure 20.4.6.

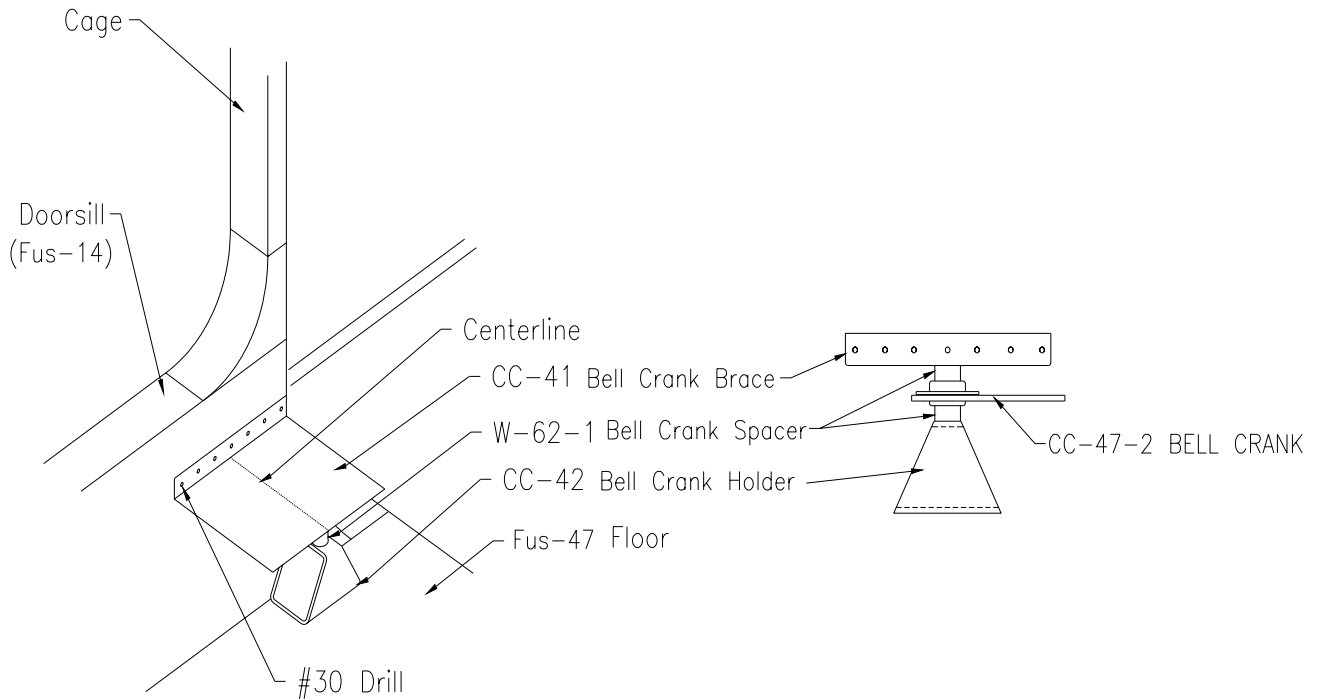

Figure 20.4.6

10) Locate and drill a 5/16" hole along the centerline for the bell crank bolt. Figure 20.4.7.

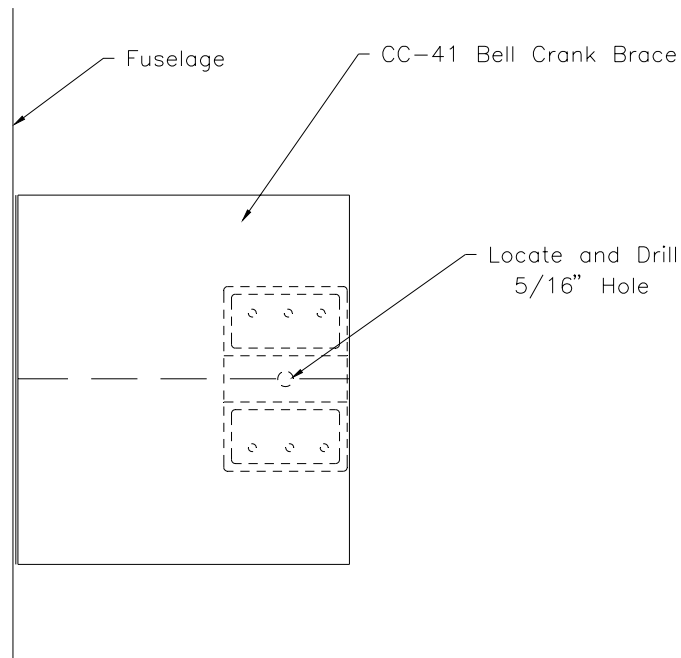

Figure 20.4.7

11) Trim the Bell Crank Brace (CC-41) as in Figure 20.4.7.

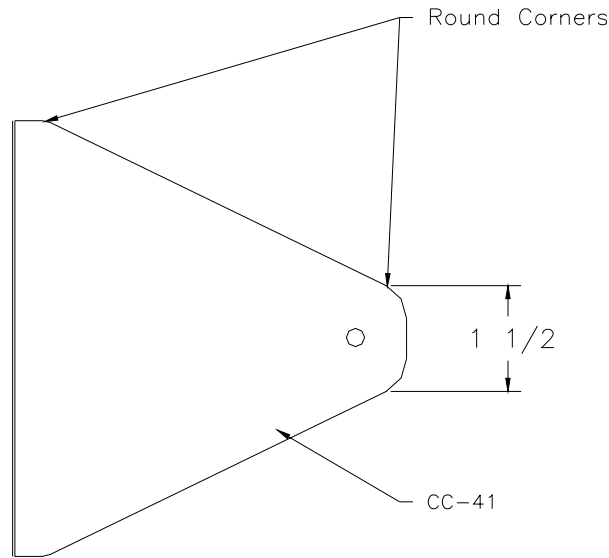

Figure 20.4.8

12) Apply a break along two edges of the Bell Crank Brace. Figure 20.4.9.

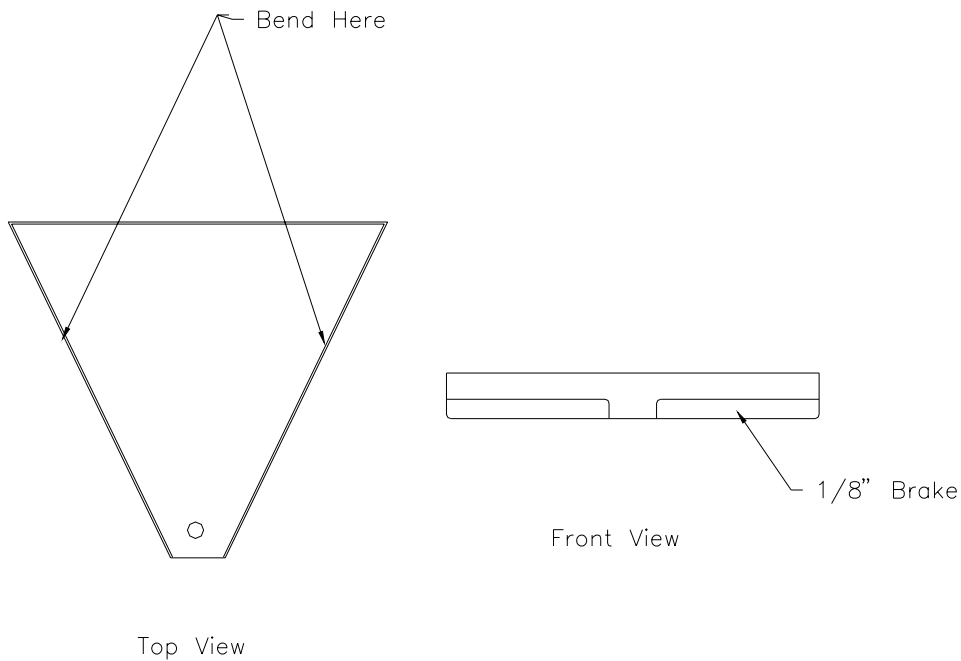

Figure 20.4.9

13) Debur all holes and edges. Rivet together with 1/8" (RV-1410) rivets.

14) Bolt the Mixer Bell Crank and Bell Crank Spacers into place with a AN5-21A bolt, AN960-516 washer and AN365-528 fiber nut. Figure 20.4.10.

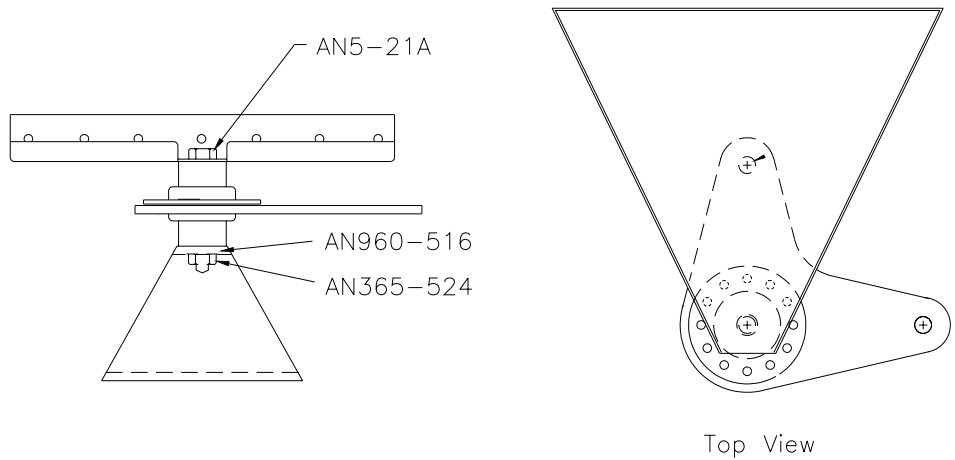

Figure 20.4.10

20.5 Mixer Install

1) Make a push-pull tube (CC-40) from 3/4" x .035 tubing (CC-51). Adjust to length by turning the rod end bearings then lock in place with a jam nut (AN316-4) on the outboard end only. Figure 20.5.1

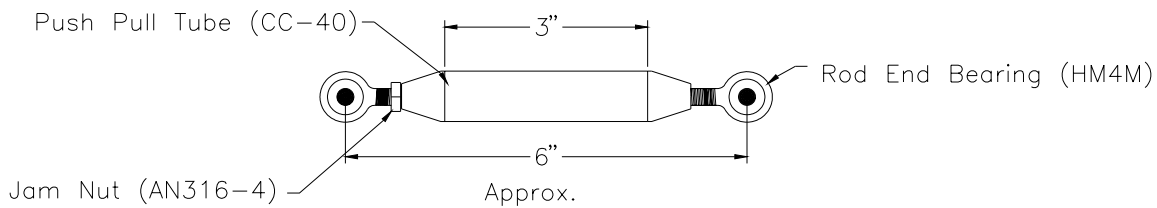

Figure 20.5.1

2) Attach one end of the push-pull tube to the pilots stick along with the connector tube. Use a couple of washers (AN960-416) if necessary to take up some space. Figure 20.5.2.

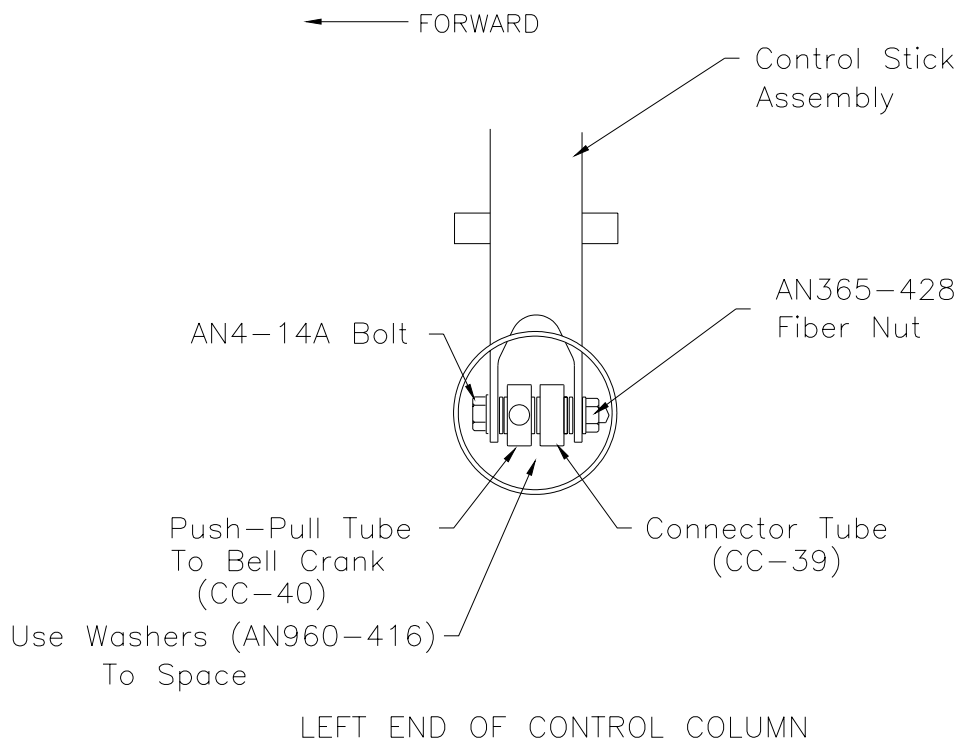

Figure 20.5.2

## 20.0 CONTROL INSTALLATION

3/2/2006

3) Adjust the push-pull tube until CC-47-2 is 90° to the control column. Figure 20.5.3.

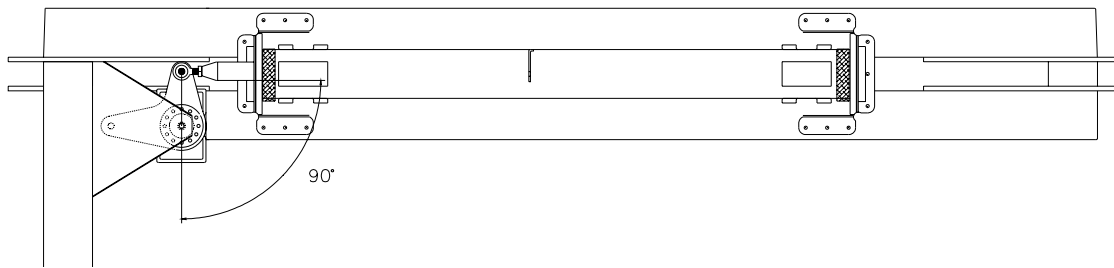

Figure 20.5.3

4) Attach the other end of the push-pull tube to the bell crank with an AN4-11A bolt, AN970-3 washer (drilled out to 1/4"), 2 AN960-416 washers, AN365-428 fiber nut. Figure 20.5.4.

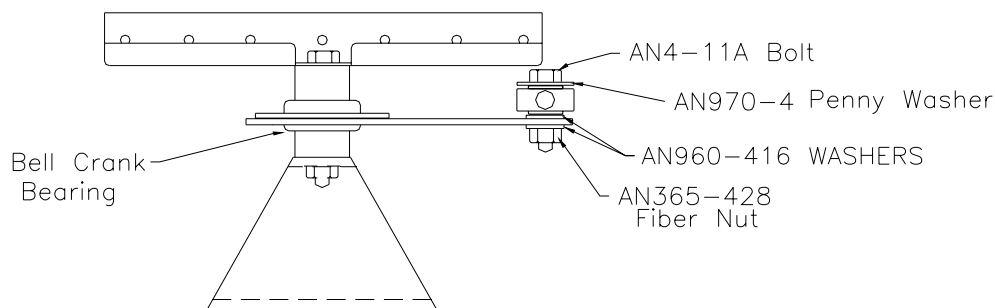
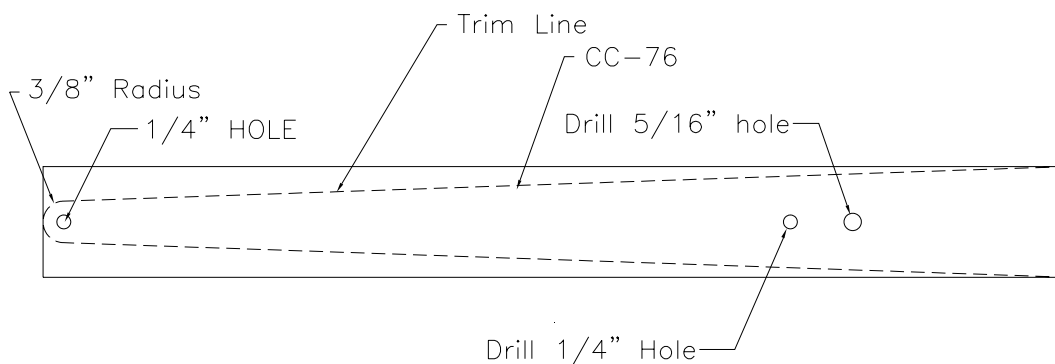

Figure 20.5.4

5) Trim mixer arm (CC-76) to the dimensions shown in figure 20.5.5.



DGM0441

Figure 20.5.5

6) Using the full size drawings, cut out the doublers for the mixer arm assembly. Drill holes as shown. Figure 20.5.6 and Figure 20.5.7. (Cut from FUS-57)

7) Put the doublers in, on the inside of the pilots door and drill #30 holes for attachment to the fuselage. Figure 20.5.8.

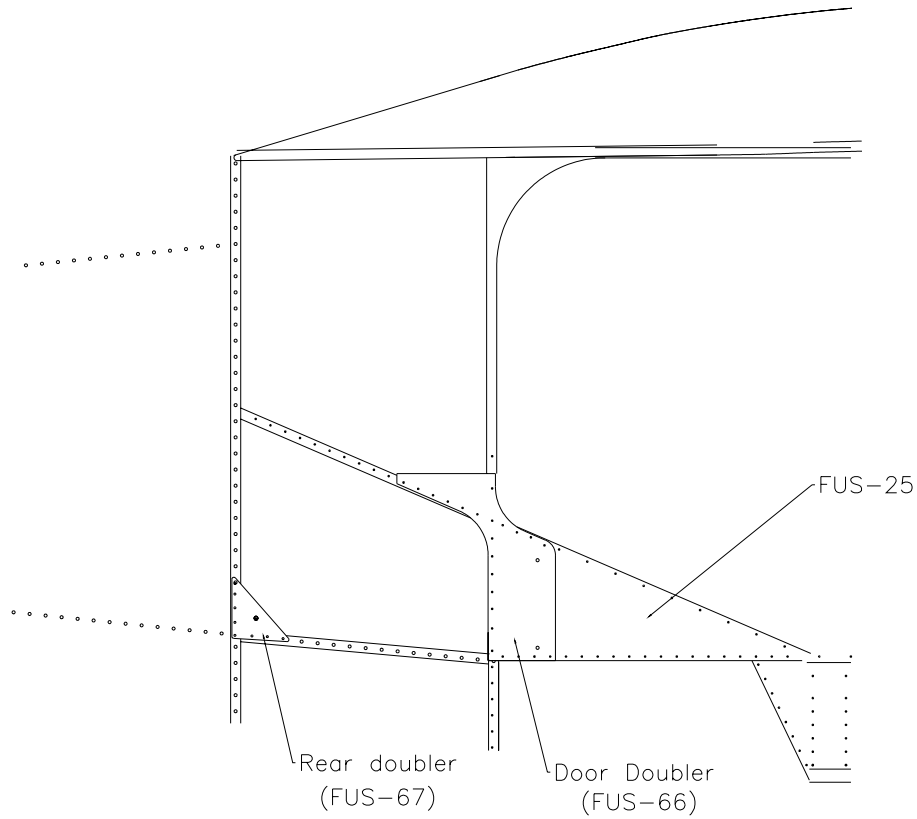

Figure 20.5.8

8) Use a felt marker to mark the location of the #11 holes on the inside fuselage skin (FUS-25).

9) Remove the door doubler and position a floating anchor nut (F5000-3) on the back side of each #11 hole.

Figure 20.5.9.

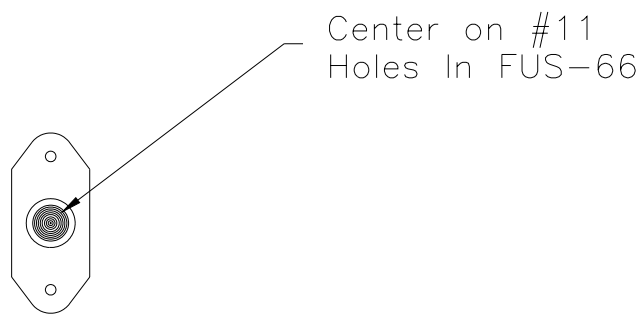

Figure 20.5.9

10) Drill the two #30 attachment holes through each floating anchor nut (F5000-3). Figure 20.5.10.

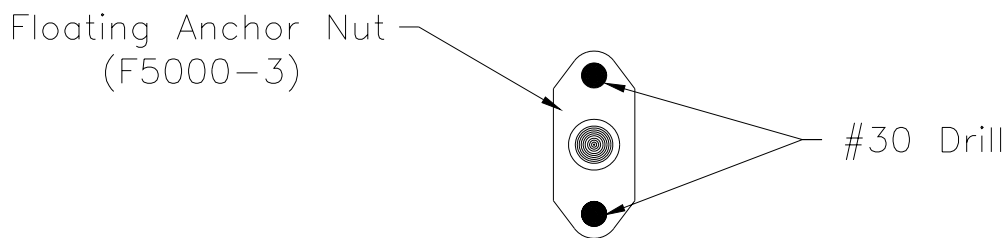

Figure 20.5.10

11) Countersink the four holes to allow countersunk rivets to sit flush.

**NOTE:** Be sure to countersink the anchor nut attachment holes on the outer side of the doubler. Figure 20.5.11.

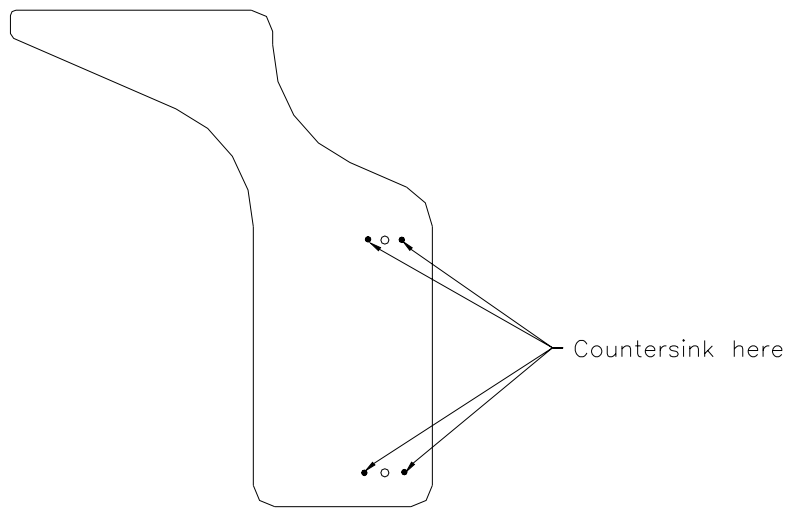

Figure 20.5.11

- 12) Debur all holes and edges.
- 13) Attach the floating anchor nuts (F5000-3) to the doubler (FUS-66). Rivet from the front side of the doubler with 1/8" CS rivets (RV-4412).
- 14) Using the marks made earlier as a guide, cut a hole large enough to allow the floating anchor nuts to enter.
- 15) Debur doublers and mating surfaces.
- 16) Rivet doublers into place with 1/8" (RV-1410) rivets.
- 17) Cut two mixer arm retainers from raw stock (CC-77) at 6" long.
- 18) Cut two spacers at 1" length from the same material.
- 19) Sand and round corners of the parts. Figure 20.5.12.

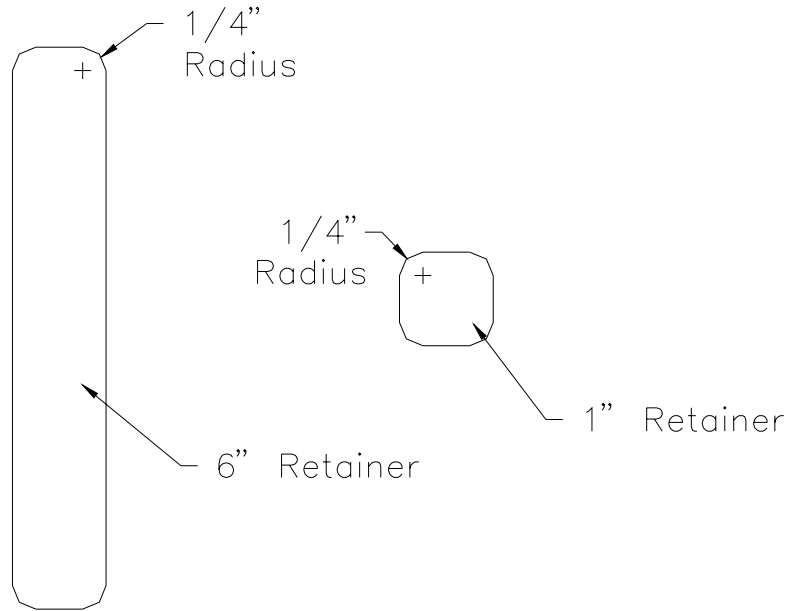

Figure 20.5.12

20) Drill two #11 holes into one 6" retainer. Figure 20.5.13.

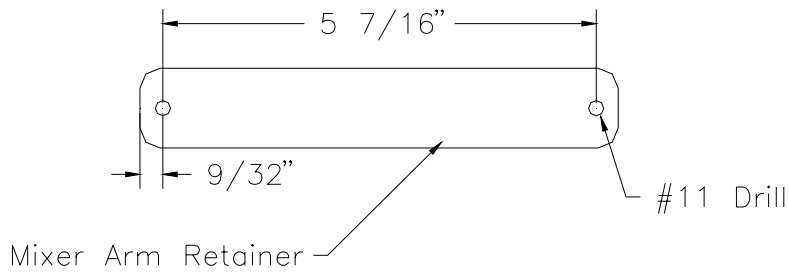

Figure 20.5.13

21) Use 6" retainer as a guide to drill the holes in the other 6" retainer and 1" spacers.

22) Bolt the retainers into position with AN3-11A bolts. Figure 20.5.14.

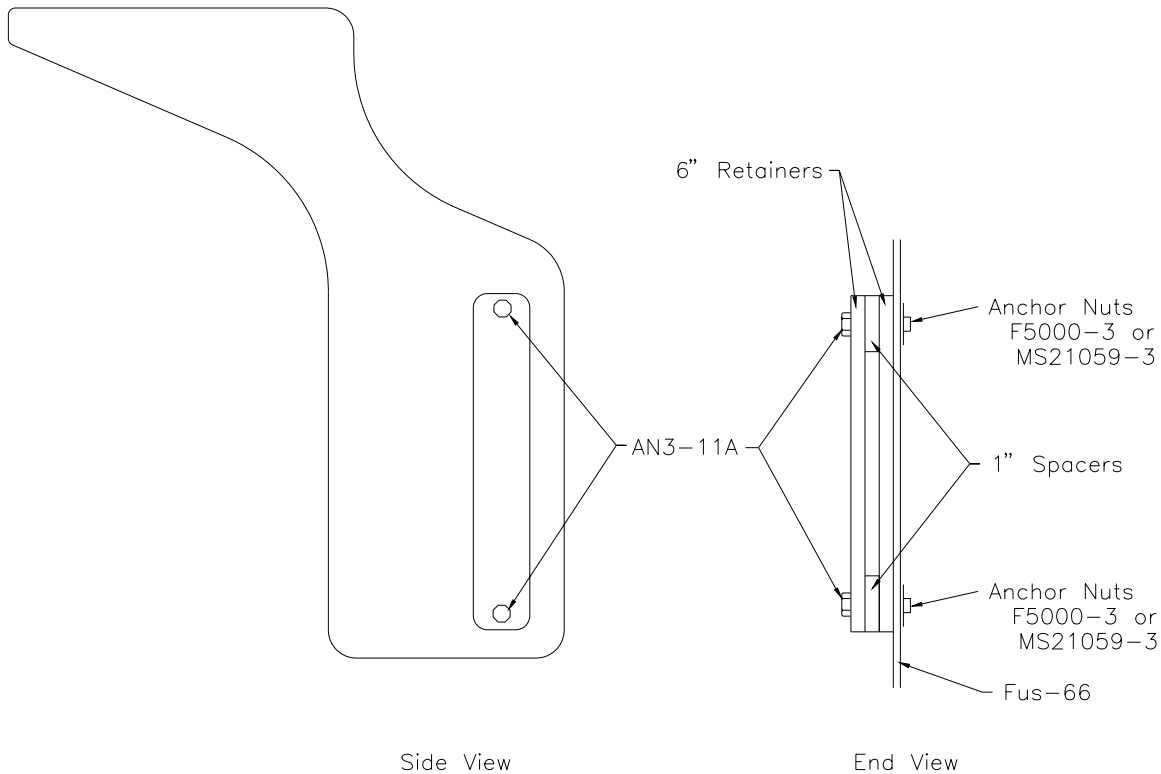

Figure 20.5.14

23) Install a Bell Crank Bearing (MI-25) in the mixer horn (CC-48-2) as done earlier.

24) Attach the mixer assembly to the mixer arm with an AN5-14A bolt, 4 AN960-516 washers, one AN970-5 penny washer and one AN365-524 fibernut. Figure 20.5.15.

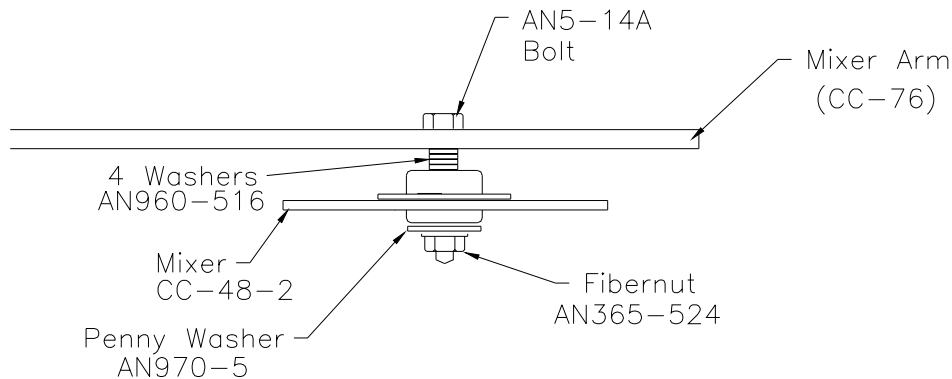

Figure 20.5.15

25) Drill the 1/4" hole in the rear doubler to 1/2" diameter.

26) Center a brass bushing (AIL-27) in the 1/4" hole on the rear doubler. Figure 20.5.16.

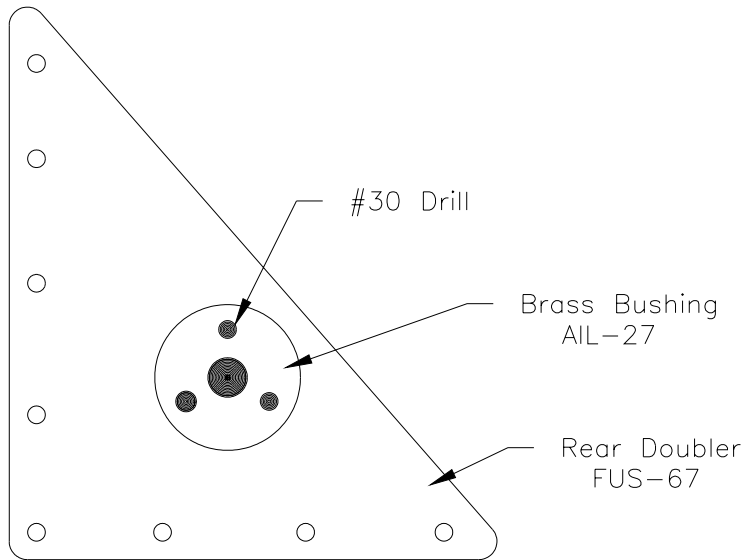

Figure 20.5.16

27) Drill three #30 attachment holes and rivet in place with 1/8" CS (RV-4412) rivets.

28) Slide the wide end of the mixer arm between the retainers and attach mixer arm to the rear doubler. The arm should move freely within the retainers. Sanding of the arm may be required. Figure 20.5.17.

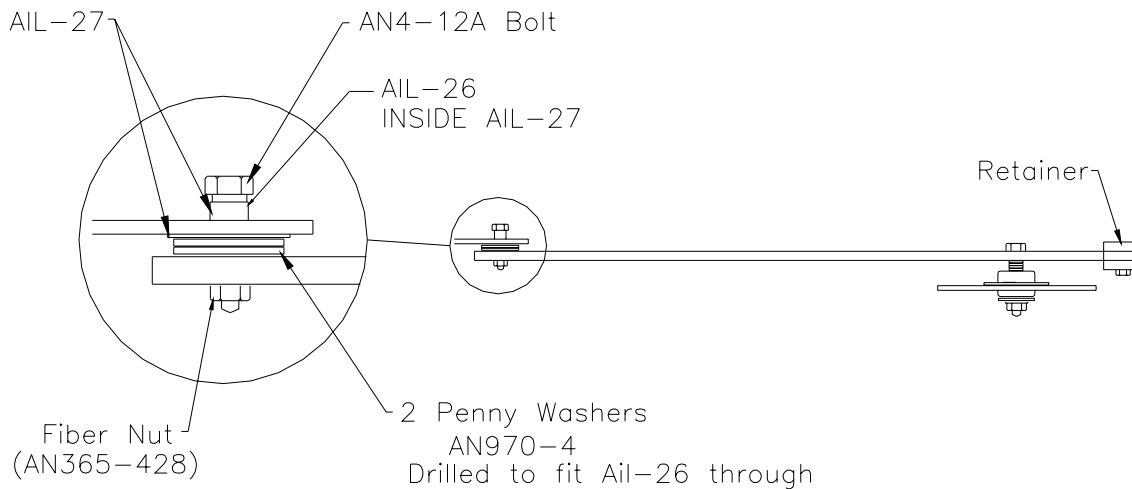

Figure 20.5.17

### 20.6 Flap Control Horn

1) With the wings attached to the fuselage, locate the position where the torque tube enters the fuselage. Mark and cut a 3" hole in each Fuselage Root Rib (FUS-27) to allow the tube to enter.

2) Cut two pieces of ST-31 channel to fit between bulkhead "F" and "G" along the roof line. Figure 20.6.1.

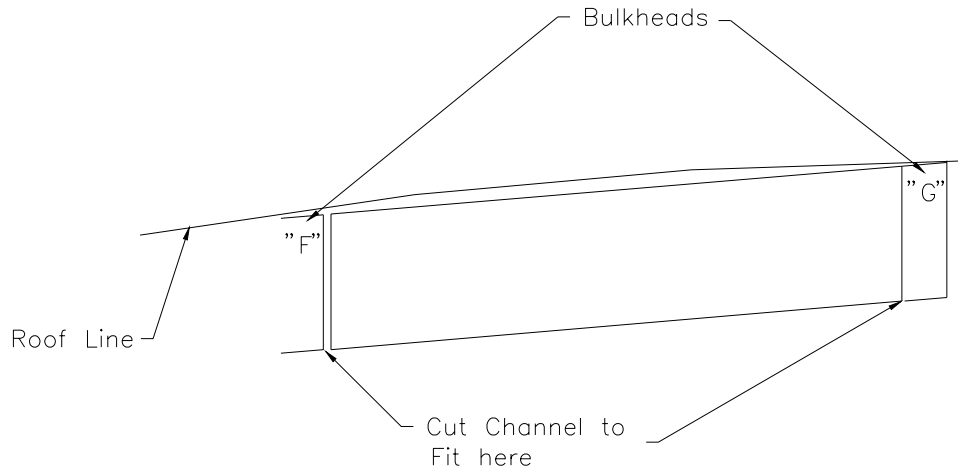

Figure 20.6.1

- 3) Cut four angles from (ST-31) for attachment and attach channel into position. Rivet angles similar to the floor channels using 1/8" rivets (RV-1410). Figure 20.6.2. **NOTE:** Do not rivet one channel in place yet. You have to final install the Hanger first.

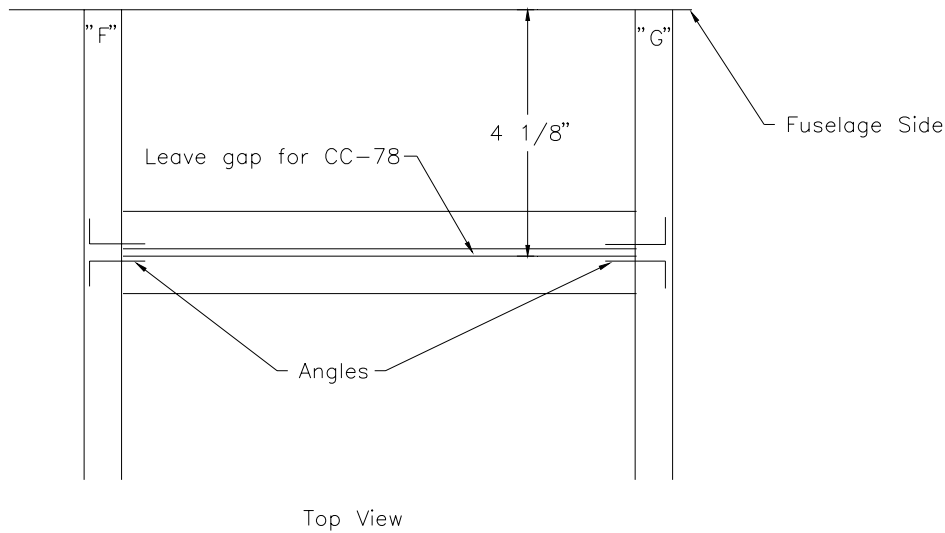

Figure 20.6.2

- 4) Cut out Torque Tube Hanger (CC-78) from .125 material (FUS-57). Figure 20.6.3.

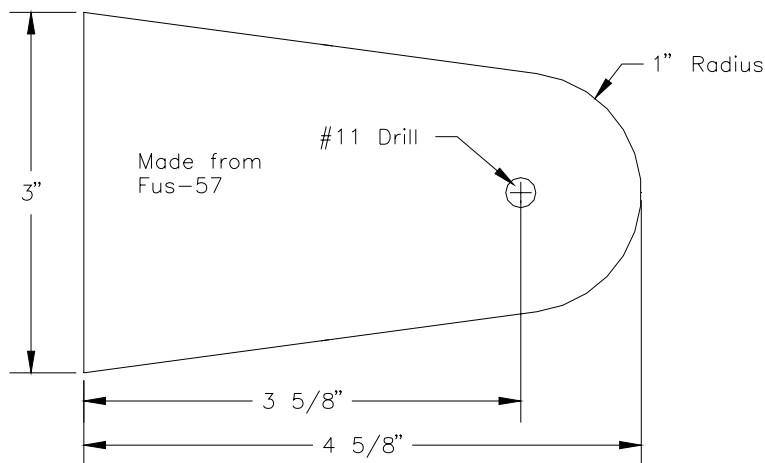

Figure 20.6.3

## 20.0 CONTROL INSTALLATION

3/2/2006

- 5) Cut two torque tubes for the inside the fuselage from 2" x .035" tube material (CC-64). Cut one tube 5 3/8" long and the other 40 1/4" long.
- 6) Install the right control horn assembly, which was made in the wing assembly, to the 40 1/4" long tube. Drill eight #11 holes through the end of the tube and end plug.
- 7) Remove and debur. Chromate and rivet with 3/16" S.S. rivets (RR-5604).
- 8) Install the left control horn assembly to the 5 3/8" long tube. Drill eight #11 holes through the end of the tube and end plug.
- 9) Remove and debur. Chromate and rivet with 3/16" S.S. (RR-5604).
- 10) Install a AN4-16A bolt into the anchor nut of each horn end plug. Tighten snugly. Grind or cut off the head of the bolt. Repeat for each horn. Figure 20.6.4.

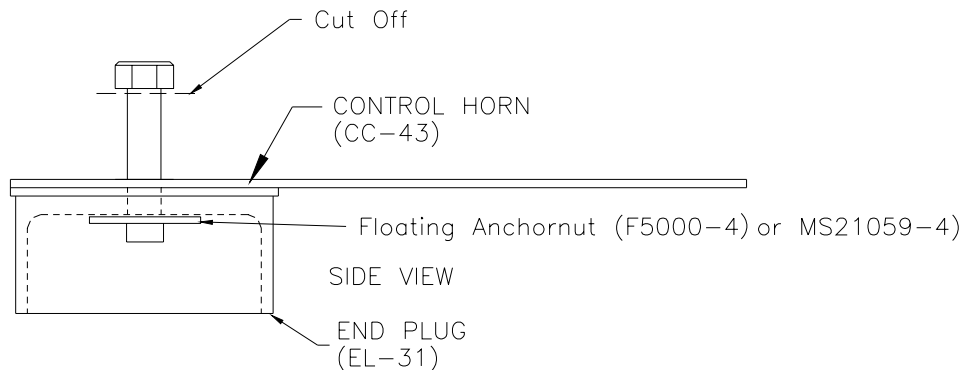

Figure 20.6.4

- 11) Make a similar horn assembly for the in-board end of each fuselage torque tube. Do not install the floating anchor nuts.
- 12) Drill the center hole of two end plugs to 3/8".
- 13) Bolt together as in figure 20.6.5 with an AN4-16A bolt, two AIL-26 metal bushings and an AN365-428 fibernut. The metal bushing should be tight against the hanger bracket. The control horns should move freely on the bushings.

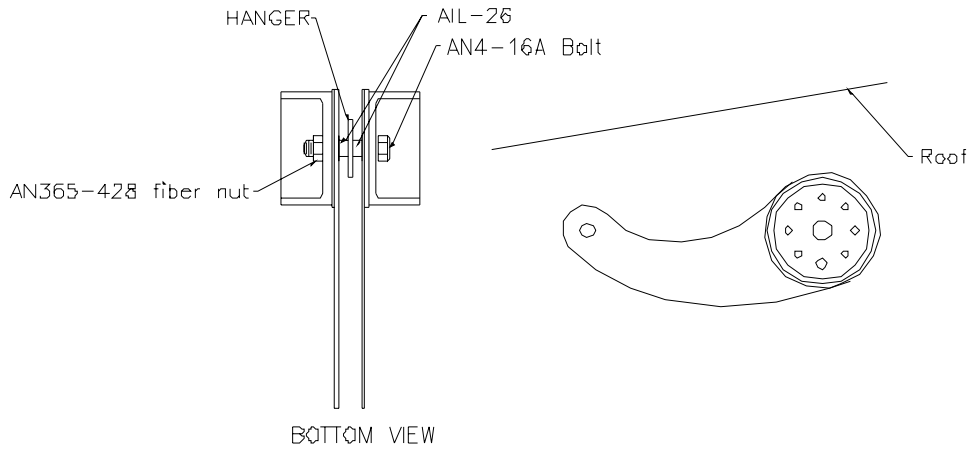

Figure 20.6.5

14) Slide the torque tubes through the holes in the fuselage and onto their corresponding end plugs.

15) Attach the wings. Ensure the bolt in the fuselage torque tube slides into the end plug of the wing torque tube. Figure 20.6.6.

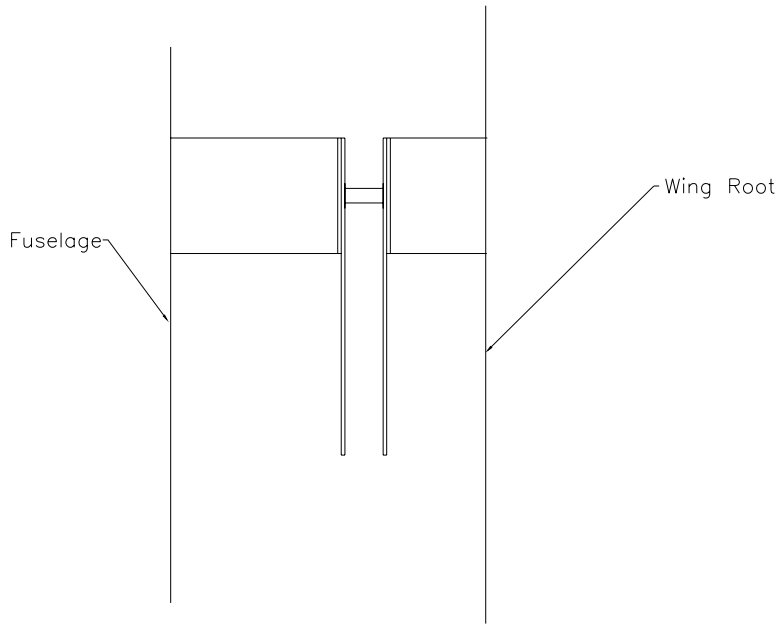

Figure 20.6.6

16) Align all torque tubes so that there is no binding at the pivot points. Locate the hanger (CC-78) position on the channel on the roof. Clamp the hanger onto the channel. Figure 20.6.7.

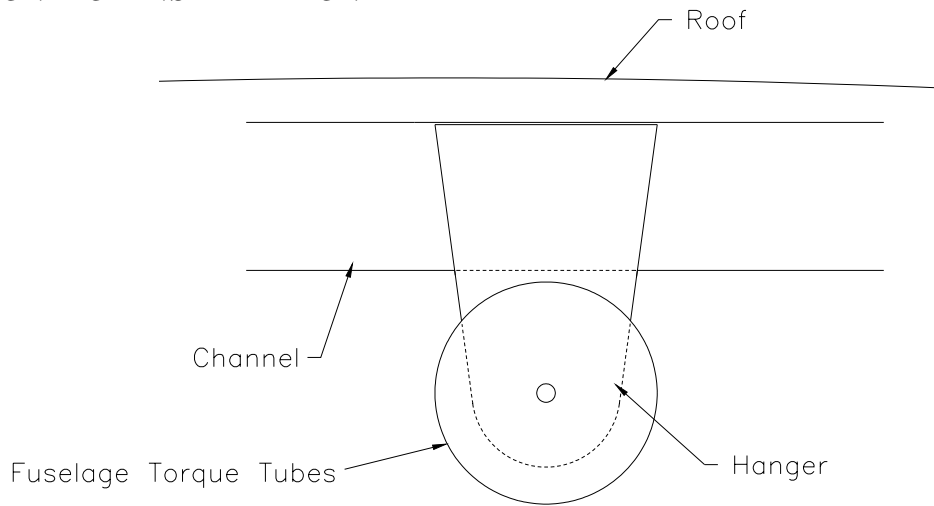

Figure 20.6.7

17) Trace the position of the hanger on to one of the channels. Figure 20.6.8.

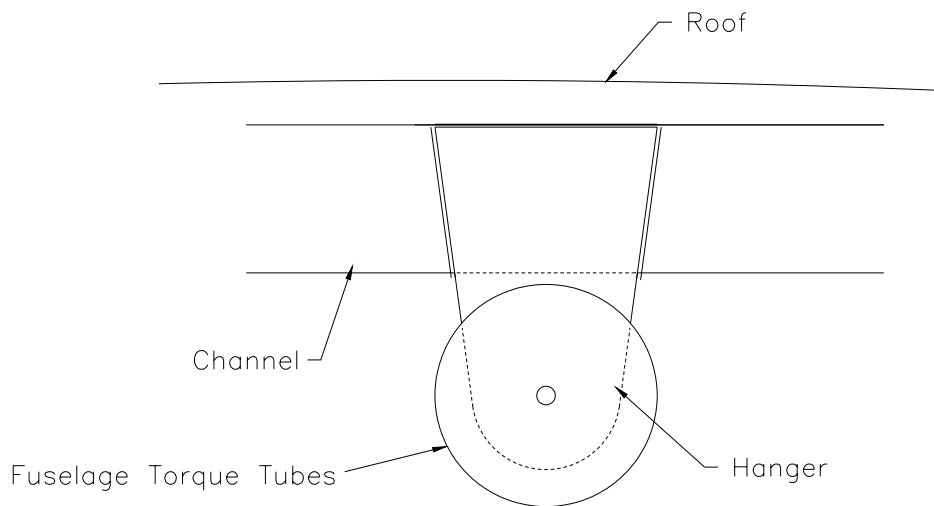

Figure 20.6.8

18) Remove wings.

19) Remove fuselage torque tubes.

20) Disconnect the horn assembly from the hanger.

21) Replace the hanger in it's location on the channel and drill six #11 holes through hanger and channel.

Figure 20.6.9.

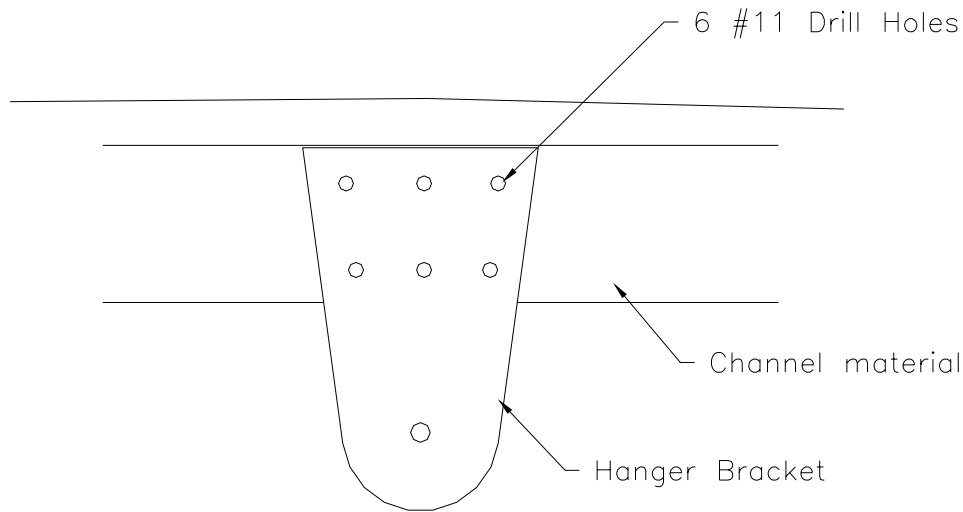

Figure 20.6.9

22) Sandwich the hanger between the two channels. Figure 20.6.10.

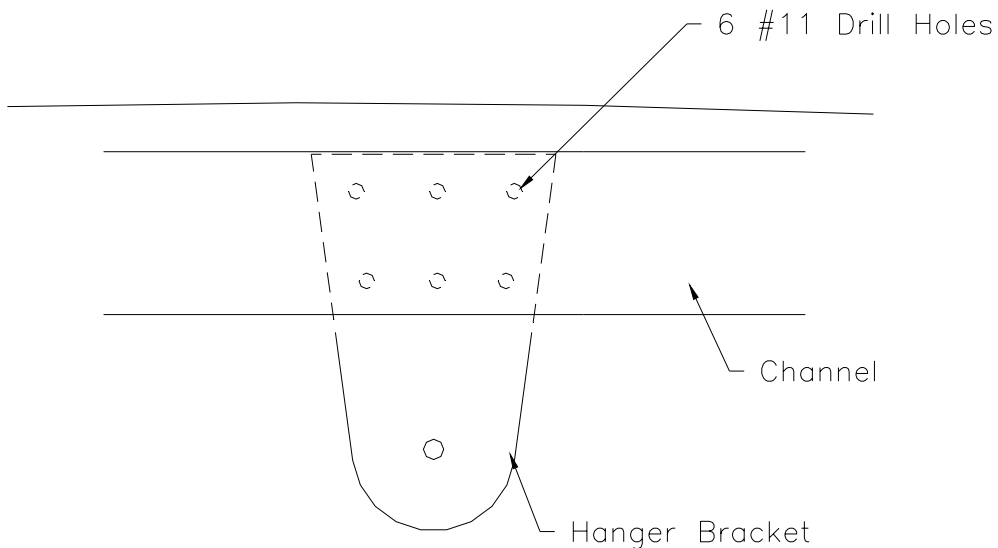

Figure 20.6.10

23) Keeping the channel tight to the hanger, back drill the six #11 holes through the channel. Cleco in place.

24) Debur all holes and rivet the second channel in place.

25) Rivet the hanger and channels together with 3/16" rivets (RV-1613).

26) From scrap .020 material fabricate a strap to go between the two channels behind the hanger to tie them together. Layout a nominal rivet pattern and rivet with 1/8" rivets. Also fabricate two gussets to tie the channels to the bulkheads.

27) Bolt the end plugs back on the hanger.

28) Slide the torque tubes through the holes in the fuselage and onto the horns.

29) Attach the wings to the fuselage.

30) With torque tubes tightly on the inside end plugs, install spacers (W-62-1) between the wing horn and the fuselage horn. It may be necessary to sand the spacers. Figure 20.6.11.

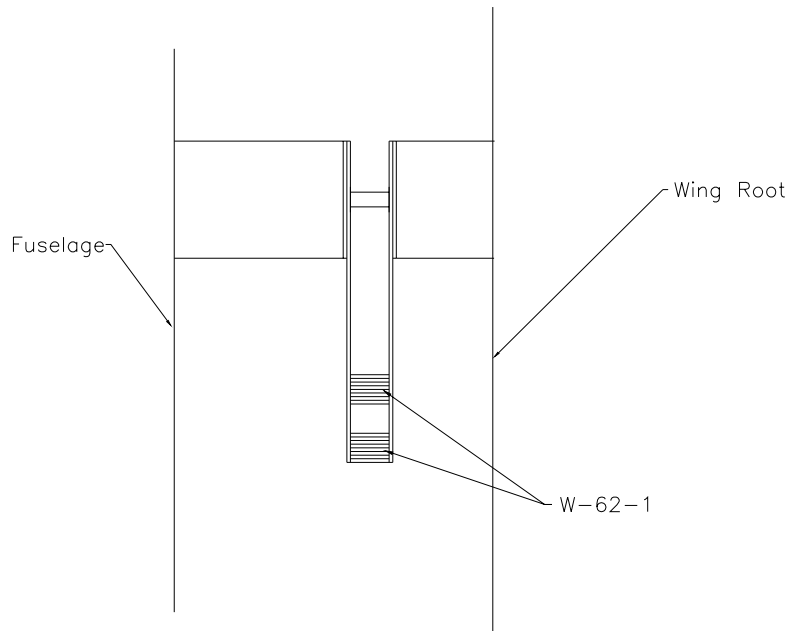

Figure 20.6.11

31) Bolt the W-62-1 spacers in with AN3-11A bolts, AN960-10 washers and AN365-1032 fiber nuts.

32) Adjust the right wing flaperons so that the trailing edge is 5 1/4" up from neutral position. Figure 20.6.12.

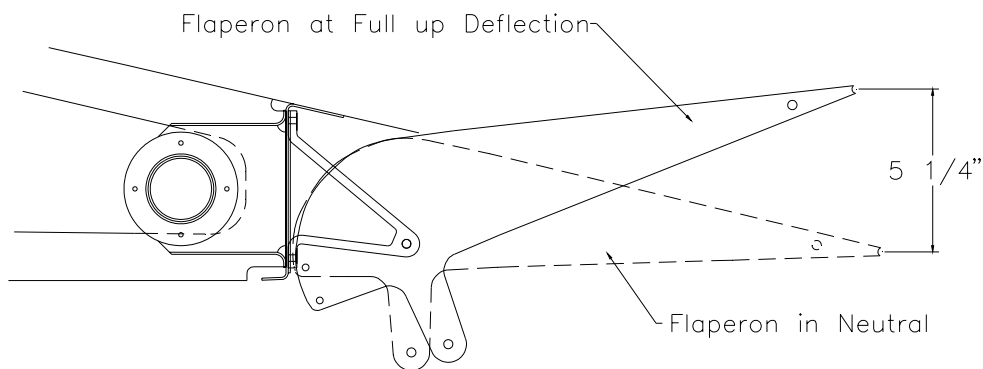

Figure 20.6.12

33) Adjust the right horn in the fuselage so that it just clears the bulkhead "F".

34) Drill a #40 hole through the torque tube and end plug. Cleco to hold in place.

35) Return flaperons to neutral.

36) Adjust the mixer arm (CC-76) so that there is 7/8" clearance between the mixer and the top spacer block. Figure 20.6.13.

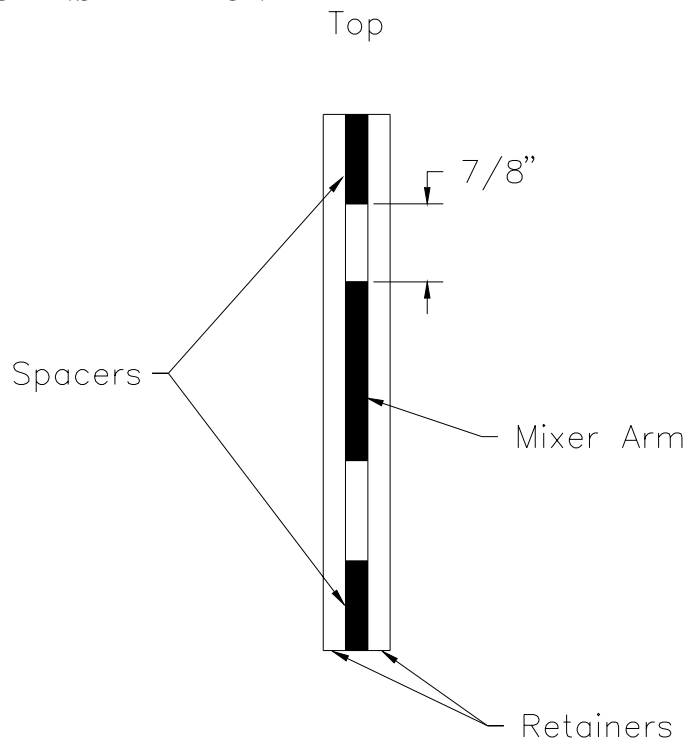

Figure 20.6.13

### 20.7 Push Pull Tubes

1) Cut a push-pull tube from 1" x .058" tube (CC-50) to fit between the bell crank (CC-47-2) and mixer (CC-48-2). Figure 20.7.1.

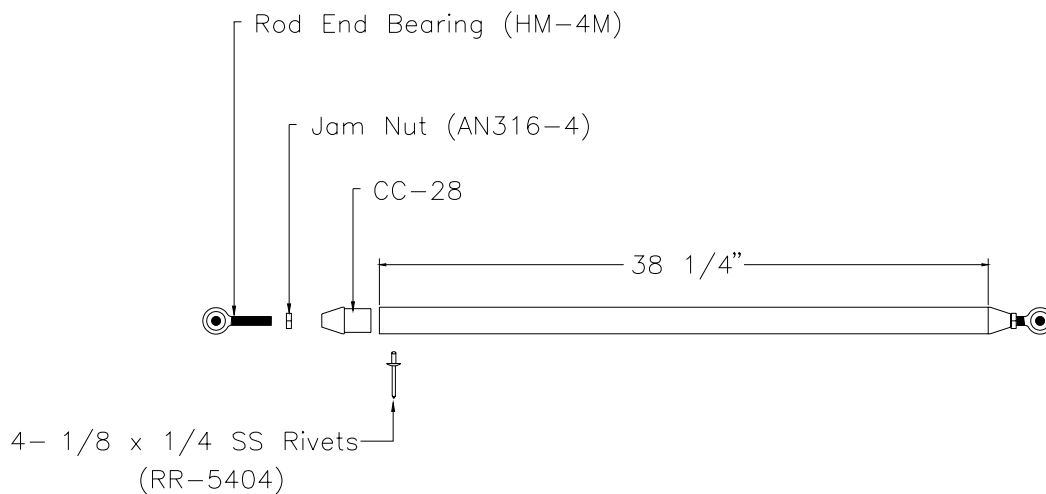

Figure 20.7.1

- 2) Attach end plugs (CC-28) and rod-end bearings (HM-4M).
- 3) Attach Push-Pull tube to the bell crank (CC-47-2) with a AN4-10A bolt, AN970-4 penny washers and AN365-428 Fiber nut.
- 4) Adjust push-pull tube so that a 90° angle is achieved between Mixer Horn (CC-48-2) and the tube when the controls are neutral.

## 20.0 CONTROL INSTALLATION

3/2/2006

- 5) Attach push-pull tube to the bell crank (CC-47-2) with a AN4-10A bolt, AN970-4 penny washer and AN365-428 fiber nut.
- 6) Countersink the two inside fuselage torque tube horns to allow a 1/4" countersunk bolt (AN509-416-R-16). Figure 20.7.2.

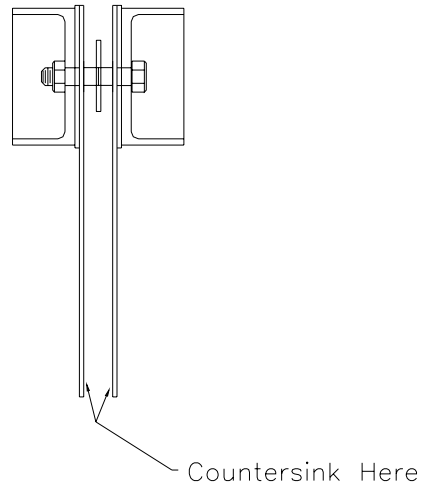

Figure 20.7.2

- 7) Adjust the aileron to the neutral position. Adjust the mixer horn (CC-48-2) to neutral.
- 8) Measure between bolt holes on the mixer arm bellcrank and horn on the torque tube.
- 9) Cut and assemble a push-pull tube from 3/4" X 0.035 tube to this measurement, in the same way as in Fig. 20.7.1. .
- 10) Adjust the rod-end bearings to fit between the mixer and horn on the torque tube. Figure 20.7.3. Bolt the push-pull tube to the torque tube horn with AN509-416-R-16 countersunk bolts, AN970-4 penny washer and AN365-428 fibernut.

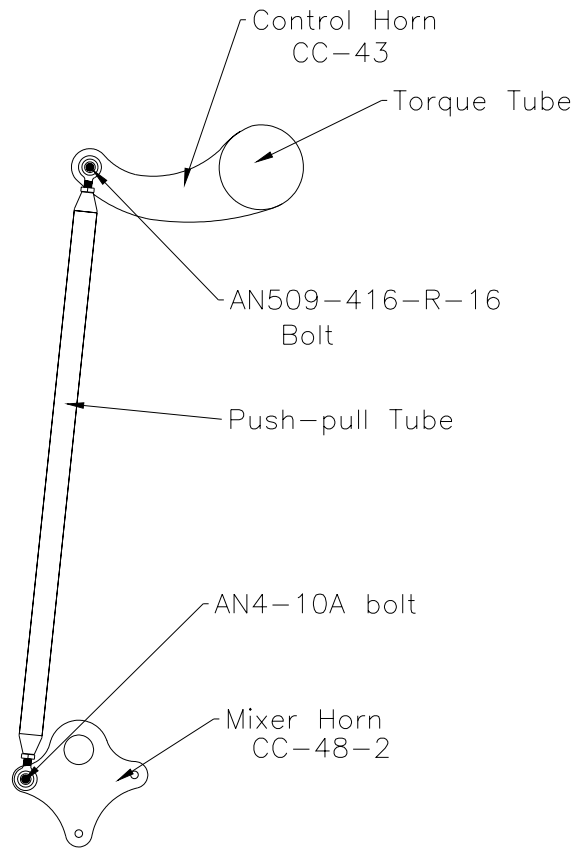

Figure 20.7.3

- 11) Bolt the push-pull tube to the mixer horn (CC-48-2) with AN4-10A bolts, AN970-4 penny washers and AN365-428 fiber nuts.
- 12) Cut and assemble a second tube in the same way to the measurement between the other two bolt holes.
- 13) Attach the tube to the Mixer.
- 14) Adjust the push-pull tube so that the angle at the left horn is the same as the right horn. Figure 20.7.4.

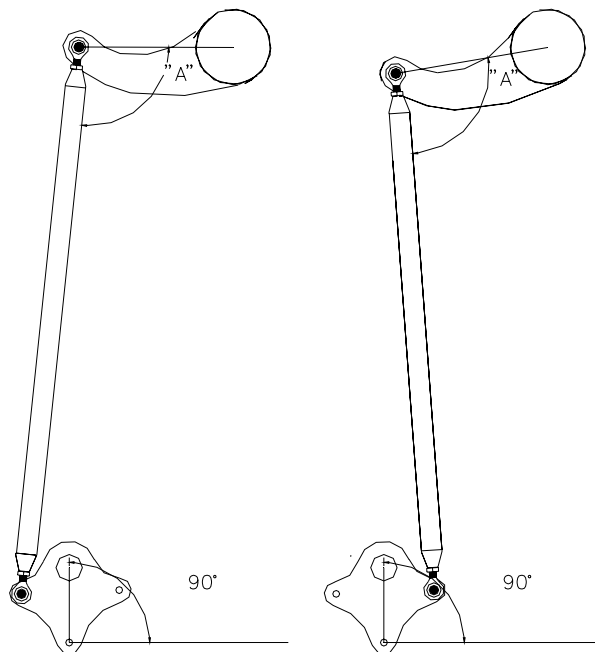

Figure 20.7.4

15) Adjust the rod-end bearings of each push-pull tube to fit between mixer and horn on the torque tube.

Figure 20.7.5. Bolt the push-pull tube to the torque tube horn with AN509-416-R-16 countersunk bolt, AN970-4 penny washer and AN365-428 fibernut.

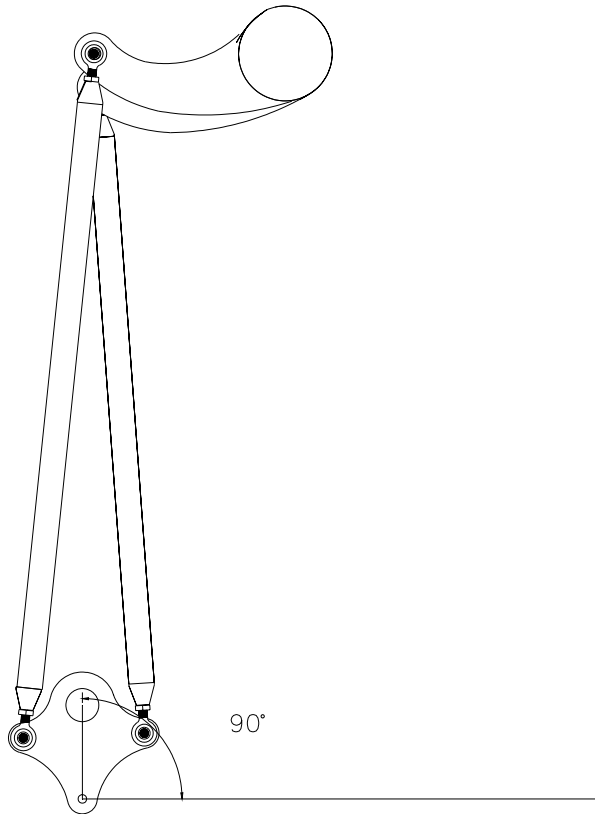

Figure 20.7.5

16) Drill a #40 hole through torque tube and end plug. Cleco.

17) Remove wings.

18) Remove fuselage torque tubes.

19) Disconnect the horn assembly from the hanger.

20) Place the end plugs into the matching torque tubes. Line up the holes and drill a total of eight #11 holes through torque tube and end plug. Figure 20.7.6.

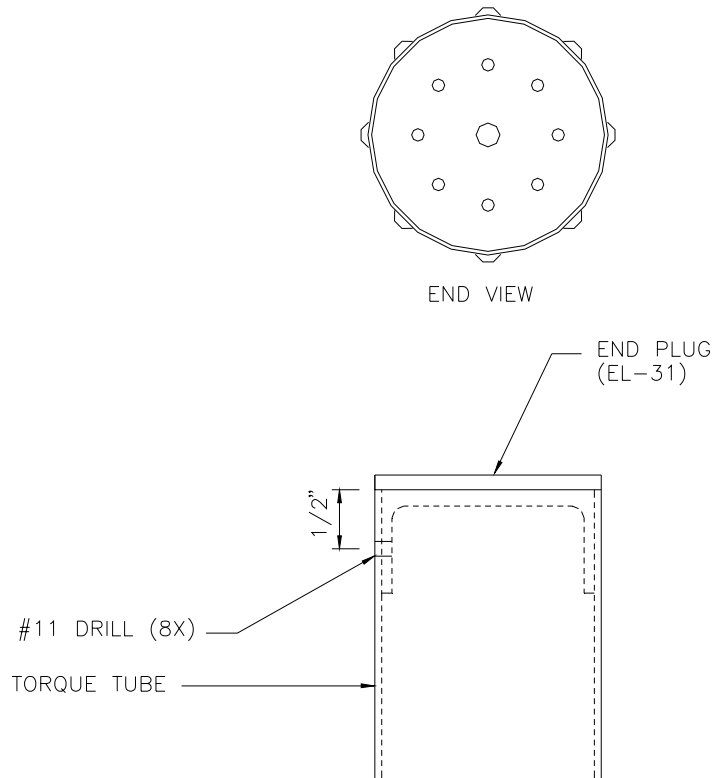
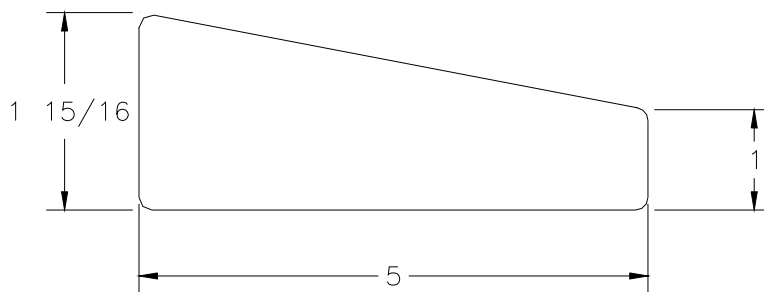

Figure 20.7.6

- 21) Bolt the inside end plugs back onto the hanger.
- 22) Slide the torque tubes through the holes in the fuselage and onto the horns. Rivet together with 3/16" S.S. rivets (RV-5604).
- 23) Bolt the push-pull tubes onto the inside horns.

### 20.8 Elevator Horn

- 1) Cut two doublers from .040 material (FUS-68). Figure 20.8.1.



DGM0399

Figure 20.8.1

- 2) Brake a 90° bend into each part to add strength. Figure 20.8.2.

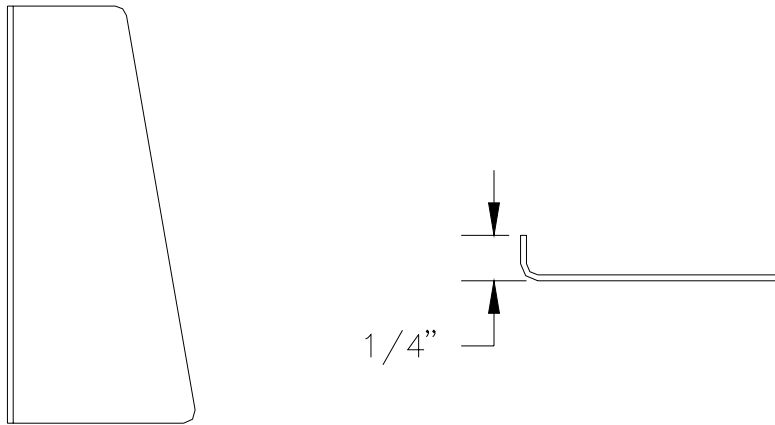

Figure 20.8.2

3) Position the doublers near outer holes on the bottom of FUS-31. Figure 20.8.3.

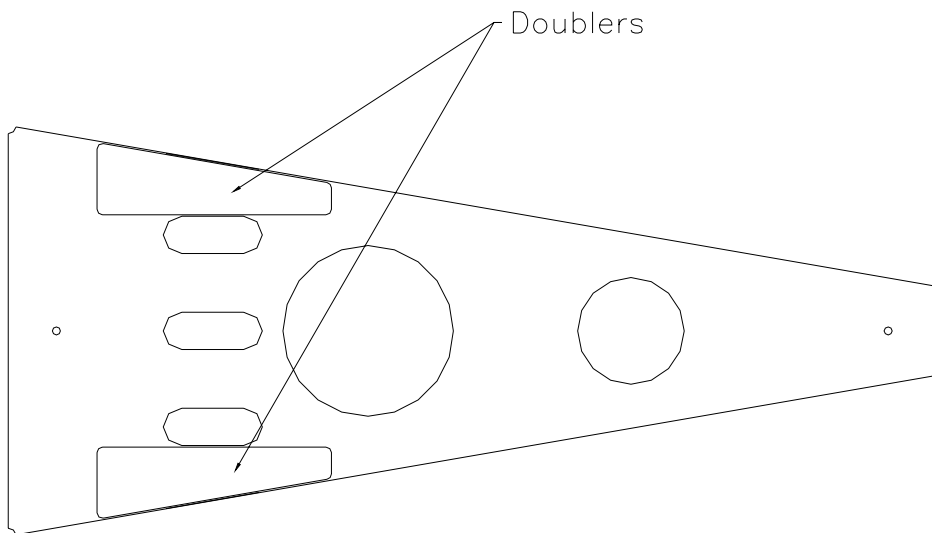

Figure 20.8.3

4) Drill four #30 holes in each end of the doublers. Figure 20.8.4.

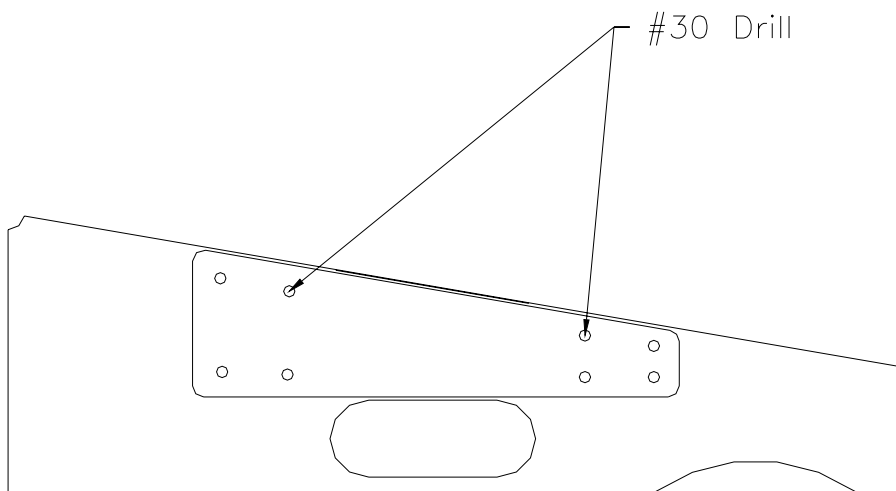

Figure 20.8.4

5) Debur holes and edges.

6) Chromate and rivet together with 1/8" (RV-1410) rivets.

7) Install two bearing blocks on the ends of the elevator horn. Center the horn in the holes of the FUS-31.

Figure 20.8.5.

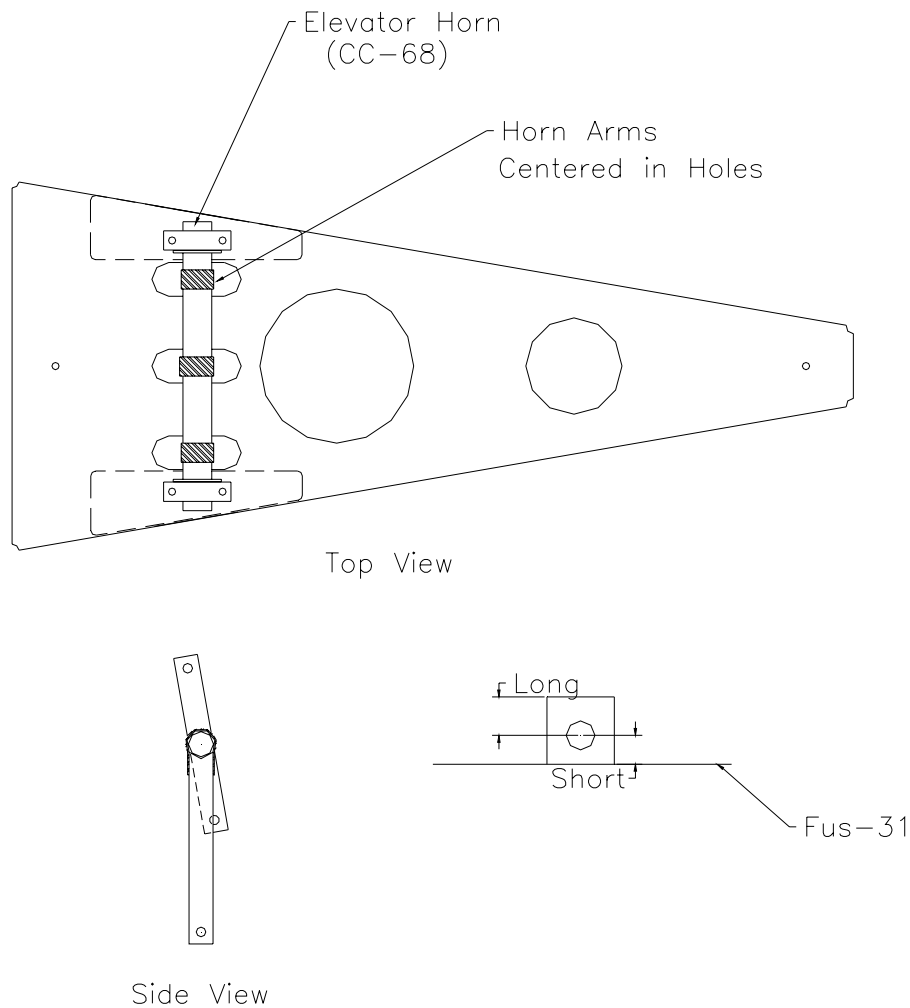

Figure 20.8.5

8) Drill #11 holes using the bearing blocks as guides, through the doublers and fuselage bulkhead. Debur.

9) Bolt together with AN3-22A bolts, AN960-10 washers and AN365-1032A fiber nuts.

10) On the sides of the tailcone measure the approximate position of the exit hole for elevator push-pull tubes. Mark the shape of the hole using a felt pen. These are not exact sizes and trimming will be necessary. Figure 20.8.6.

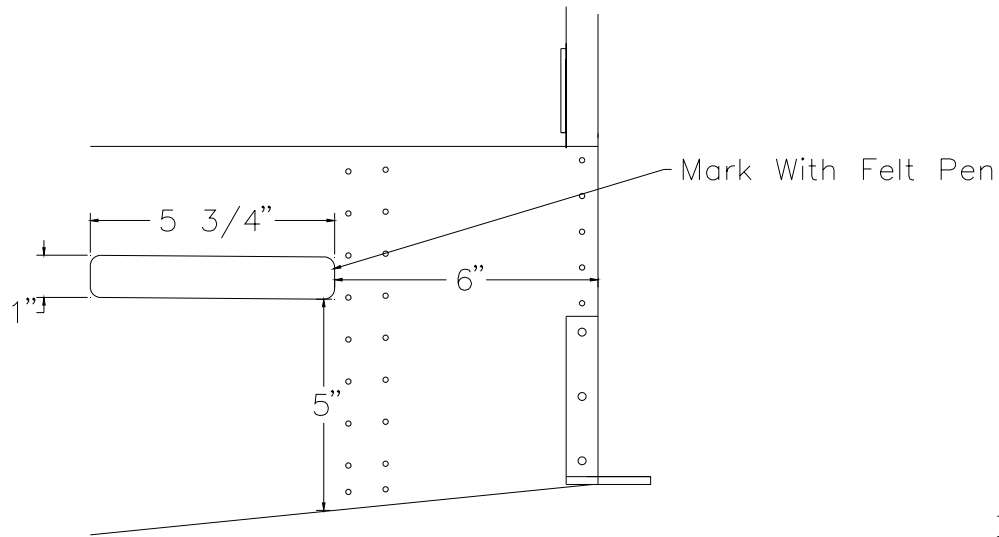

Figure 20.8.6

11) Drill 1/4" holes just inside of each corner of the marked outline. Figure 20.8.7.

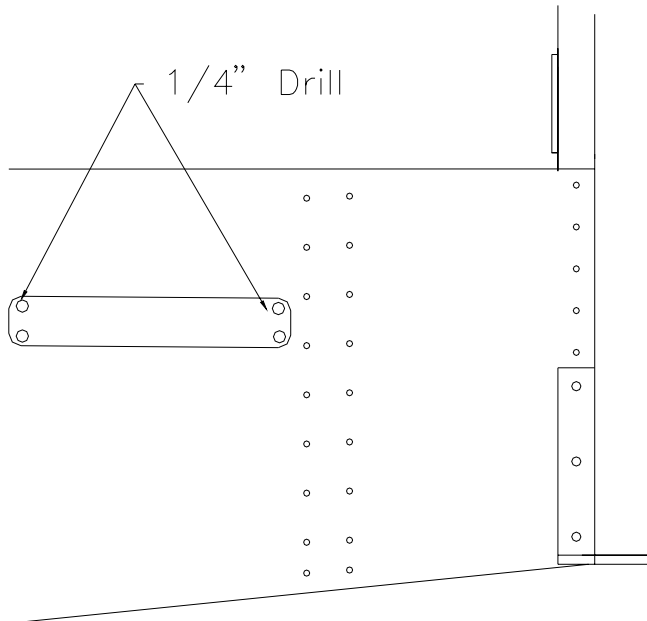

Figure 20.8.7

12) Cut out between the holes, allowing 1/8" clearance inside the lines.

13) Cut two elevator push-pull tubes (CC-75) from 3/4" x .035 tubing (CC-51) and install end plugs and hardware. Figure 20.8.8.

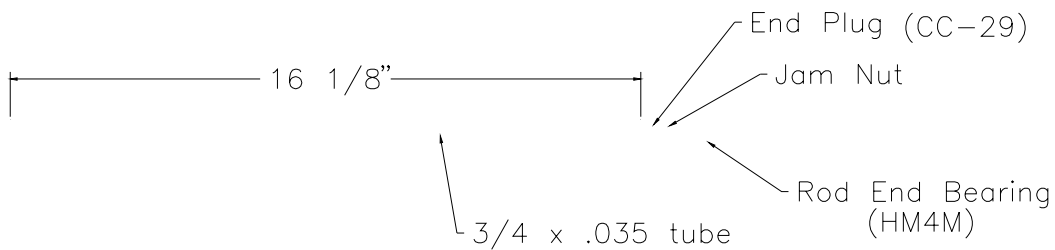

Figure 20.8.8

**NOTE:** Stabilizer and elevator must be installed before this section can be completed.

## 20.0 CONTROL INSTALLATION

3/2/2006

14) Attach the elevator push-pull tube to the elevator horn with AN4-10A bolt, AN960-416 washers for spacers and AN365-428 fiber nut.

15) Adjust the elevator push-pull tube so that the elevator is neutral when the elevator horn is neutral.

Figure 20.8.9.

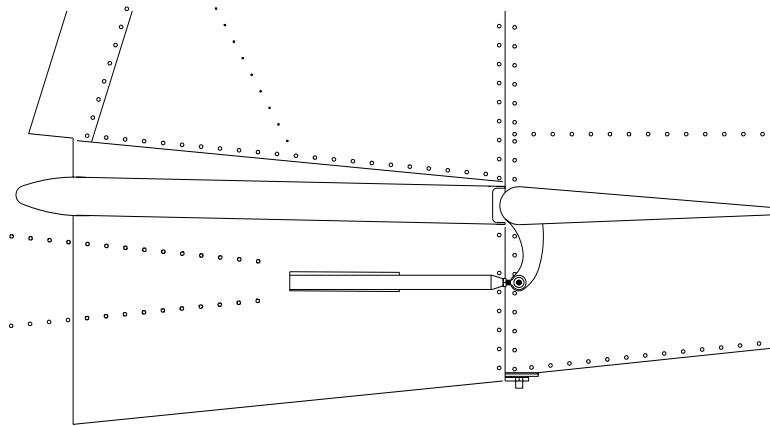

Figure 20.8.9

**NOTE:** It may be necessary to sand the exit hole to do this adjustment.

16) Trim the opening to allow 25° up and 25° down deflection of the elevator.

17) Disconnect and remove the push-pull tubes.

18) Mark and cut a .032 doubler from W-143 to strengthen the opening. Mark from the inside of the fuselage onto the doubler the shape of the hole. Make the doubler 1" larger than the cutout.. Figure 20.8.10.

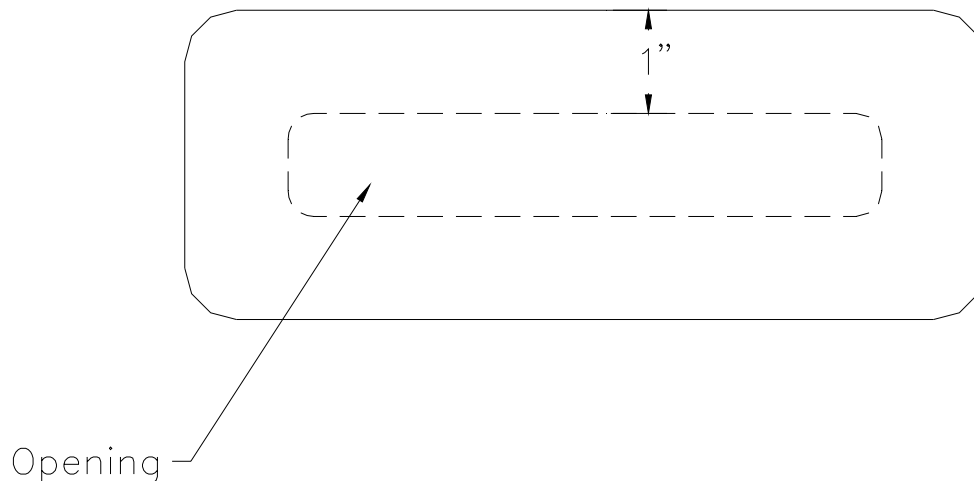
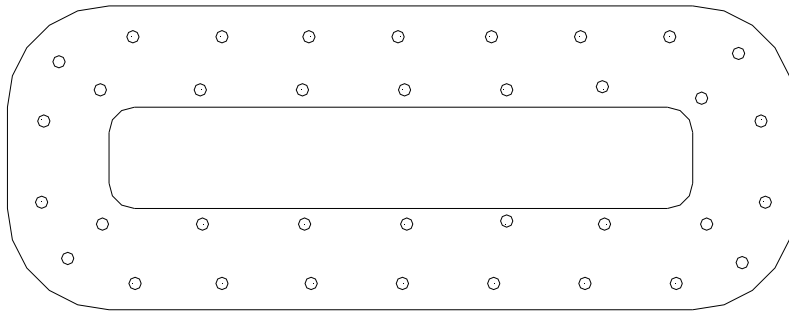

Figure 20.8.10

19) Deburr all edges.

20) Hold the doubler in place and drill #30 hole through doubler and fuselage tail wrap. Figure 20.8.11.



Approximate 1" Spacing

Figure 20.8.11

- 21) Debur and chromate mating surfaces. Rivet on with 1/8" (RV-1410) rivets.
- 22) Repeat steps for the other side.
- 23) Attach the wings.
- 24) Install the spacers and bolts between the fuselage torque tubes and the wing torque tubes.

### 20.9 Teleflex Cable Install

- 1) Attach the teleflex cable to the mixer arm with the clevis fork assembly (31800-4192). Figure 20.9.1.

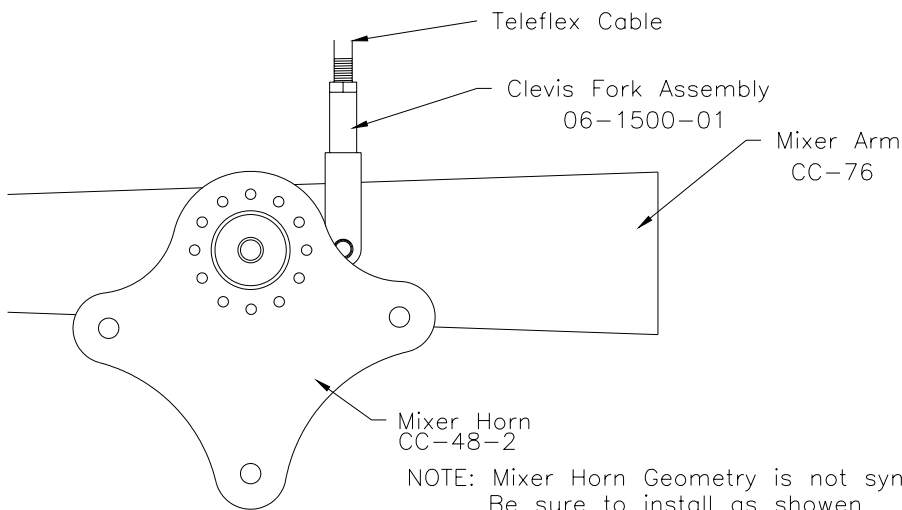

Figure 20.9.1

- 2) Slide the cable through its full travel and set the cable to that a 1/4 of the full cable travel is showing at the mixer arm (CC-76).
- 3) Position the teleflex cable retainer over the cable and use it as a guide to drill the two #11 holes into FUS-66 door doubler. Figure 20.9.2.

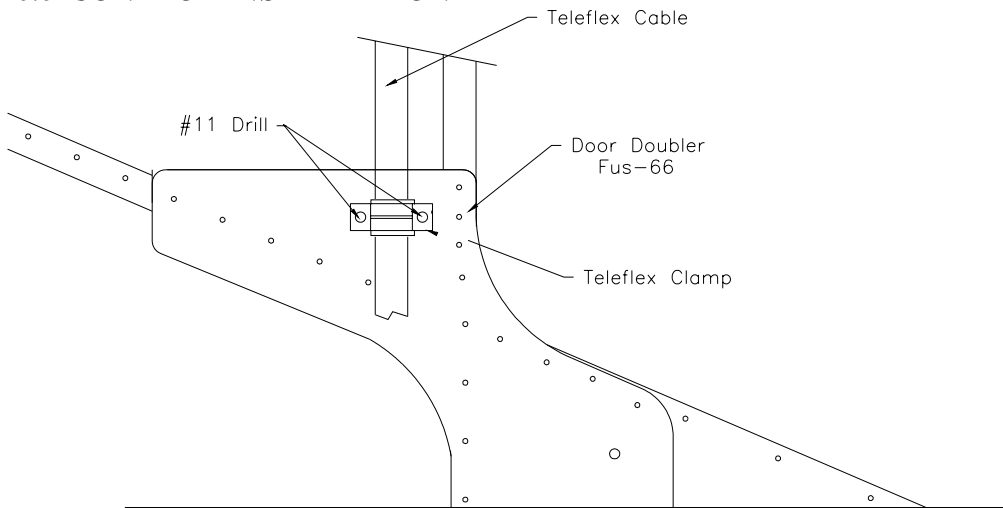

Figure 20.9.2

4) Bolt the cable retainer to the door doubler with AN3-5A bolts, AN960-10 washers and AN365-1032 fiber nuts.

### 20.10 Cable Guide Install

1) Position elevator cable guides in a straight line from the tabs on the control column to the pulleys at the end of the floor in the rear of the aircraft. Ensure that the cable will not interfere with the seatbelt bracket. Figure 20.10.1.

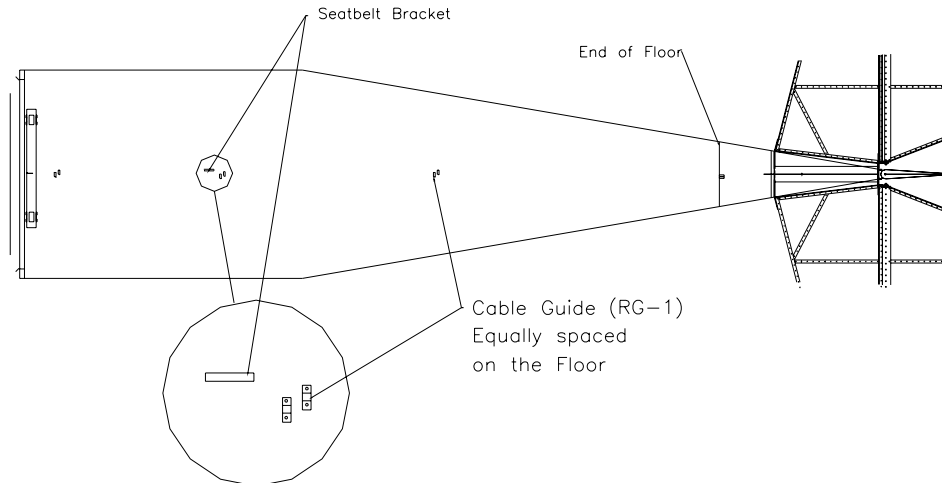

Figure 20.10.1

2) Drill #30 mounting holes for each guide and rivet using 1/8" aluminum rivets (RR-7408).

### 20.11 Elevator Cable

1) Assemble 1/8" cable and bolt to the elevator horn. Figure 20.11.1.

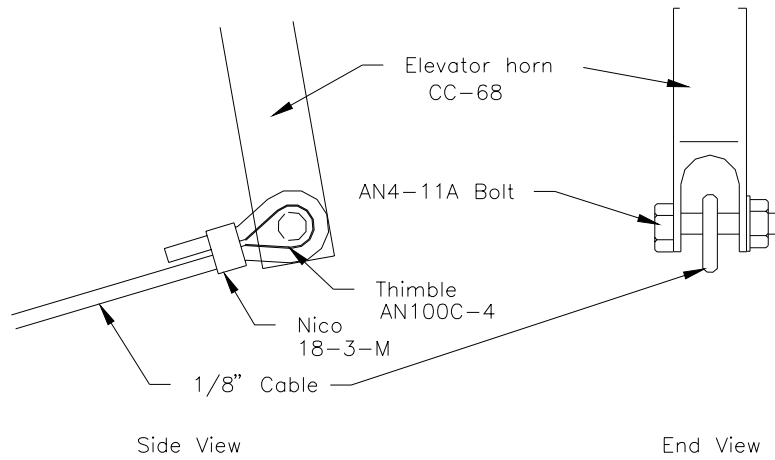

Figure 20.11.1

- 2) Run the cable through the cable guides to the control column.
- 3) Attach turnbuckles (AN130-22S) to the control column. Attach cable to turnbuckles. Figure 20.11.2.

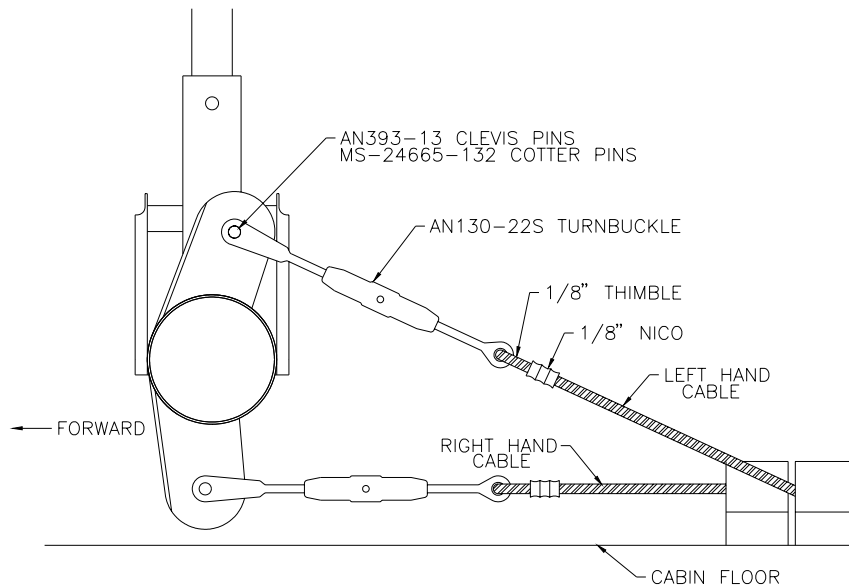

Figure 20.11.2

- 4) Position the cable cover (FUS-64) over the cable between the first and last cable guides. Then drill through each flange #30 holes at 1" spacing.
- 5) Rivet the cable cover to the floor using 1/8" rivets (RV-1410).
- 6) Locate and install cable guides for the rudder cable along the inside walls of the fuselage. Ensure cable clears the mixer controls. Keep cable as straight as possible. Figure 20.11.3.

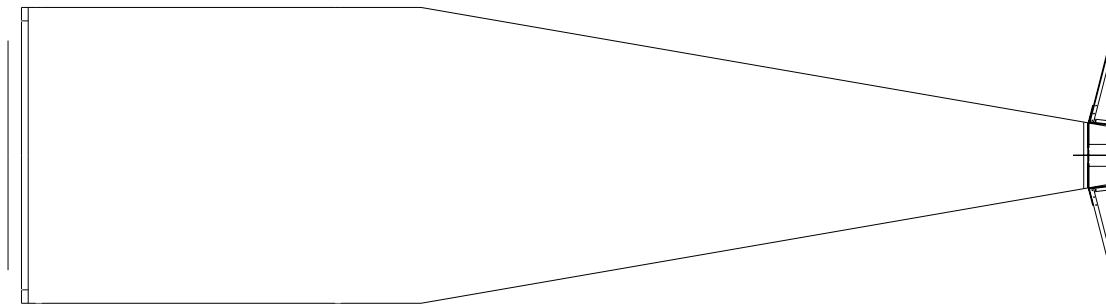
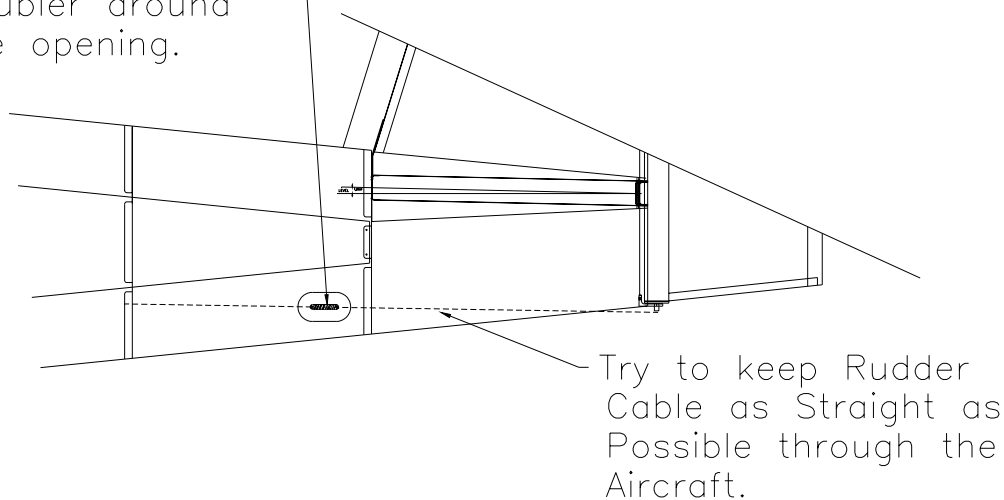

Figure 20.11.3

7) Run 1/8" cable along the guides from the rudder pedals to the back through the guides.

8) Locate the approximate location of the exit point for the cable. Drill two holes and cut out between as in Figure 20.11.4.

Rudder cable hole made as small as possible with a 1" doubler around the opening.



Try to keep Rudder Cable as Straight as Possible through the Aircraft.

Figure 20.11.4

9) Run the cable through the slot to the rudder. File the hole if necessary to allow the cable free movement with adequate clearance.

10) Assemble cable and attach to the outermost holes in the rudder horn. Figure 20.11.5.

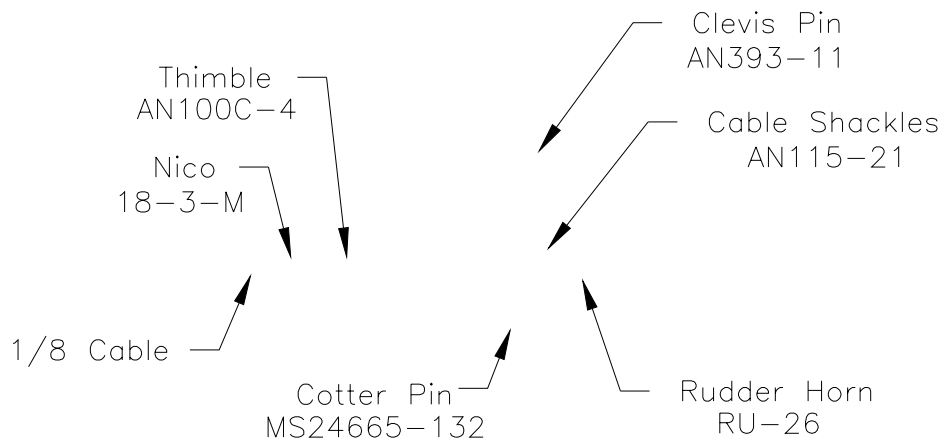

Figure 20.11.5

11) Repeat for the other side.

12) With the rudder pedals in neutral position, attach the rudder cables to the T12-HT4 tangs on the rudder pedal eyebolts using an AN100C-4 Thimbel. figure 20.11.2.

### 20.12 Flap Control

1) Cut the flap rib (FUS-65R) to fit between front three bulkheads. Figure 20.12.1.

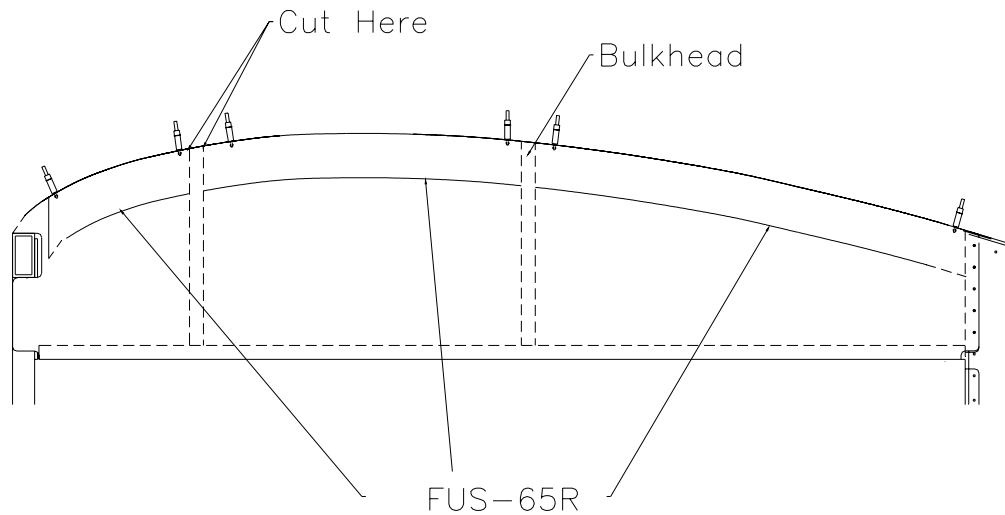

Figure 20.12.1

2) Drill #30 holes back through each end of the flap rib channel and roof. Cleco in place.

3) Drill remaining holes at 1" spacing.

4) Cut angle brackets from FUS-35 to attach the flap ribs to each bulkhead. Figure 20.12.2.

**NOTE:** This is done similar to the floor channel installation.

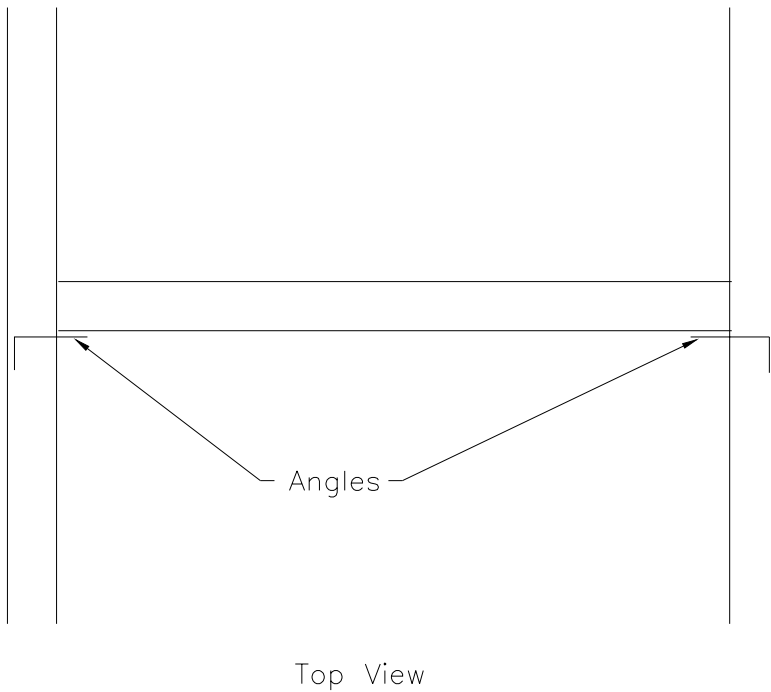
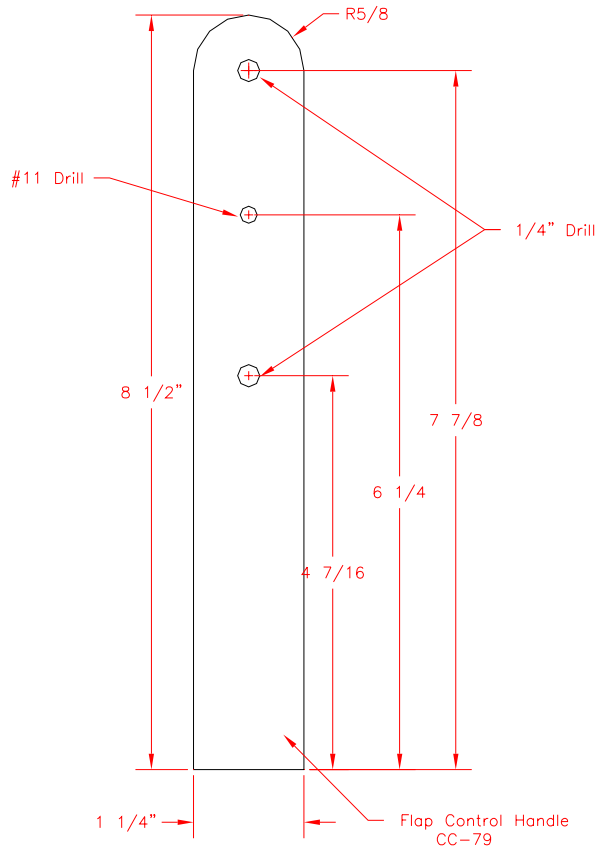

Figure 20.12.2

- 5) Debur parts. Chromate mating surfaces.
- 6) Rivet together with 1/8" rivets (RV-1410).
- 7) Using figure 20.12.3 as a template cut a flap handle (CC-79) out of .125" material (FUS-57).
- 8) Cut a flap guide (CC-80) out of .125" material (FUS-57). Use the full size figure 20.12.4 as a guide.



DGM0496

Figure 20.12.3

9) Drill and rivet a .020 doubler strip along the flap rib. Figure 20.12.5. (1" Spacing is recommended)

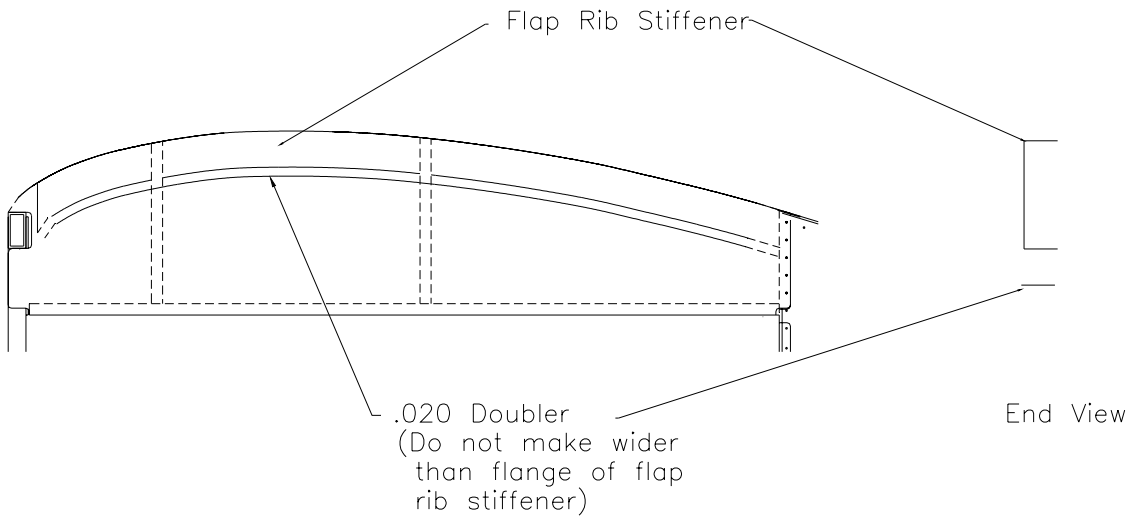

Figure 20.12.5

10) Position the flap guide on the flap rib. Figure 20.12.6.

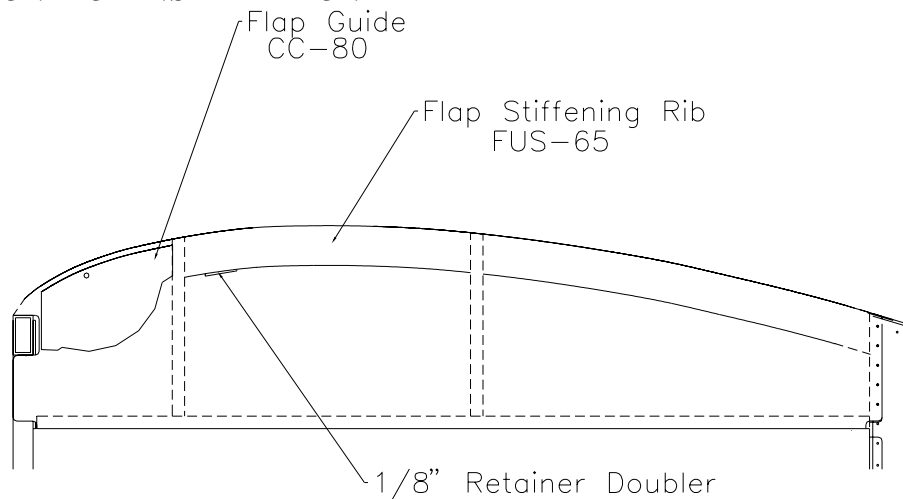

Figure 20.12.6

- 11) Clamp in place and drill the 1/4" hole through the flap rib. Cleco in place.
- 12) Drill eleven #11 holes to attach flap guide to rib. Figure 20.12.7.

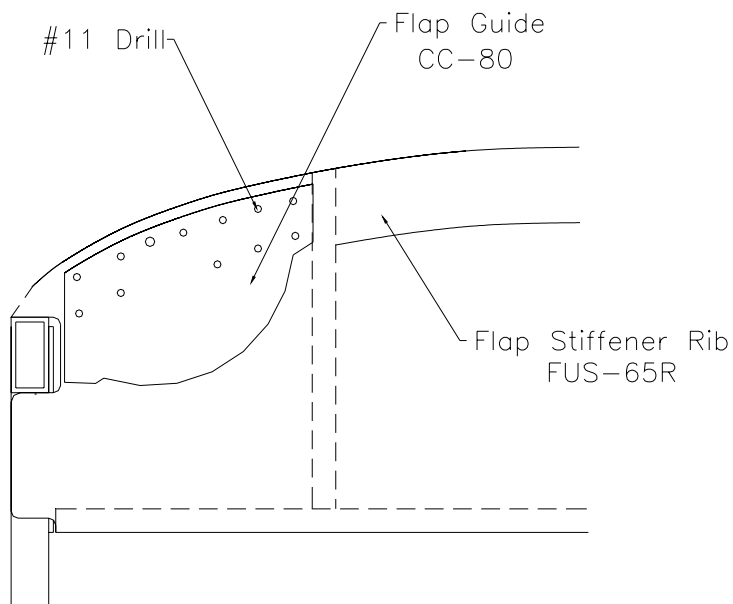

Figure 20.12.7

- 13) Attach the top hole of the flap handle (CC-79) to the flap guide (CC-80) with AN4-10A bolts.
- 14) Attach teleflex cable to the center hole of the handle.
- 15) From scrap .125 material, make a doubler to mount the teleflex retainer (31509) to the flap rib.
- 16) Attach doubler to the flap rib with 1/8" avex rivets.
- 17) Position the doubler and drill #11 holes to mount it to the flap rib. Remove, debur and chromate the mating surface. Rivet to the flap with 3/16" x 1/8" avex rivets (RV-5604).
- 18) Bolt cable retainer to doubler with AN3-6A bolt.
- 19) Place a felt pen in the center hole of the flap handle and mark a line along the length of travel.

## 20.0 CONTROL INSTALLATION

3/2/2006

- 20) Center the controls. Adjust the flap handle so that there is 7/8" space between the mixer arm and the top spacer. Mark the location of the hole in the flap handle onto the flap guide.
- 21) Mark a spot on the line 1/2" forward of the mark. This is for the reflex position.
- 22) Mark 3 spots on the line at 1/2" spacing rearward from the mark made earlier. This is for the flap positions.
- 23) Drill 1/4" holes at the five marks. Debur.
- 24) Cut the head off a AN4-10A bolt. Install a AN316-4 Jam Nut. Insert the AN4-10A bolt into the flap handle and attach with AN316-4 Jam Nut. Figure 20.12.8. Sand bolt as necessary to allow smooth operation of flaps.

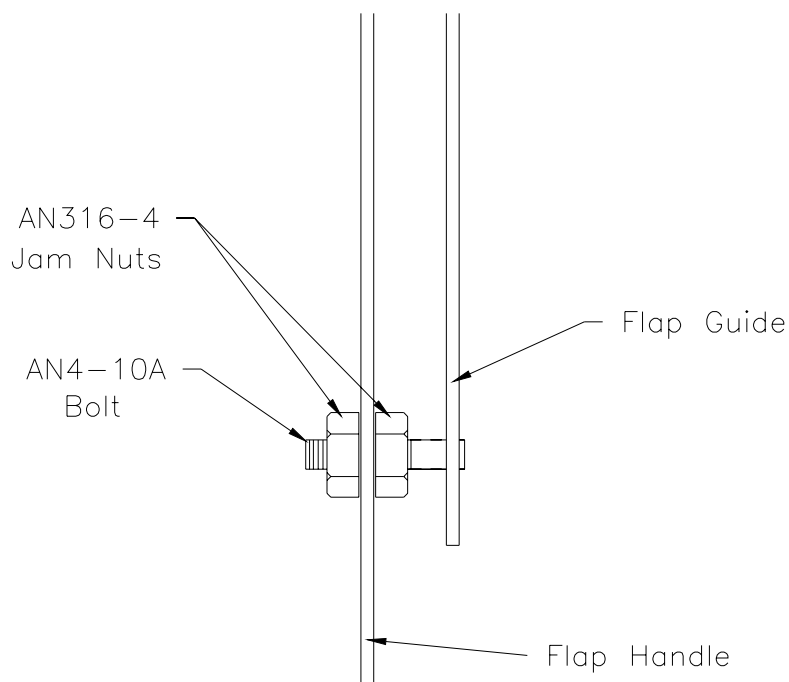

Figure 20.12.8

- 25) Adjust and safety wire the turnbuckles on the rudder pedals and control column.