

1650  
Landing Gear

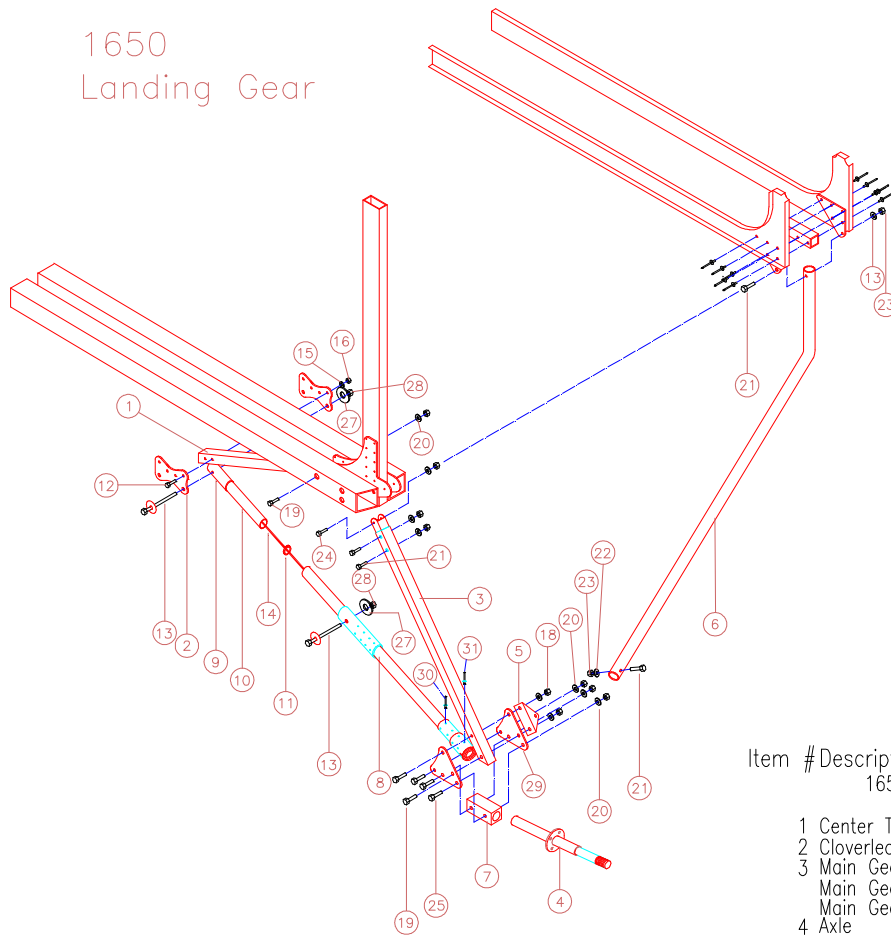

Item #	Description	Part-No.	Required
1650 LANDING GEAR			
1	Center Tube	LG-26	2
2	Cloverleaf Center Gusset	LG-27-1	2
3	Main Gear Leg(consist of:	LG-44	2
	Main Gear Leg	LG-33	
	Main Gear Leg Doubler	LG-34	
4	Axle	LG-105	2
5	Drag Brace Gusset	LG-41	2
6	Drag Brace Assembly	LG-13-1	2
7	Axle Block	LG-39	2
8	Lower Slide Tube(consist of:	LG-43	2
	Lower Slide Tube	LG-37	
	Slide Tube Outside Doubler	LG-35	
	Slide Tube Outside Triple	LG-36	
	Lower Slide Tube Sleeve	LG-40	
9	Upper Slide Tube Doubler	LG-4	2
10	Upper Slide Tube	LG-5	2
11	Slide Tube Bumper Disk	LG-6-1	2
12	3/16" Bolt	AN3-15A	4
13	3/8" Bolt	AN6-35A	4
14	Safety Cable Assembly		2
15	3/16" Washer	AN960-10	4
16	3/16" Fiber Nut	AN365-1032	4
18	5/16" Fiber Nut	AN365-524	14
19	5/16" Bolt	AN5-20A	6
20	5/16" Washer	AN960-516	14
21	1/4" Bolt	AN4-15A	8
22	1/4" Washer	AN960-416	8
23	1/4" Fiber Nut	AN365-428	8
24	5/16" Bolt	AN5-16A	2
25	5/16" Bolt	AN5-17A	6
27	3/8" Penny Washer	AN970-6	8
28	3/8" Fiber Nut	AN365-624	4
29	Main Gear Leg Gusset	LG-32	4
30	1/8" x 3/16" Avex Rivet	RV-1410	48
31	1/8" x 5/16" Avex Rivet	RV-1414	16

To assemble the landing gear will require the following tools:

1. Variable speed hand drill.
2. #11, 1/4", 5/16", 3/8" drill bits.
3. Quantity of 3/16" clecos.
4. Deburring tool.
5. Felt marker.
6. Tape measure
7. 3/8", 7/16", 1/2", 5/8" wrenches.
8. Nico press.
9. Cable cutters or cold chisel and hammer.

Approximate time for this job is 6 hours.

### 15.1 Slide Tube Assembly

- 1) Place the fuselage upright on two sawhorses. **NOTE:** Skins are removed for clarity.
- 2) Drill out front landing gear attach points to 5/16". Figure 15.1.1.

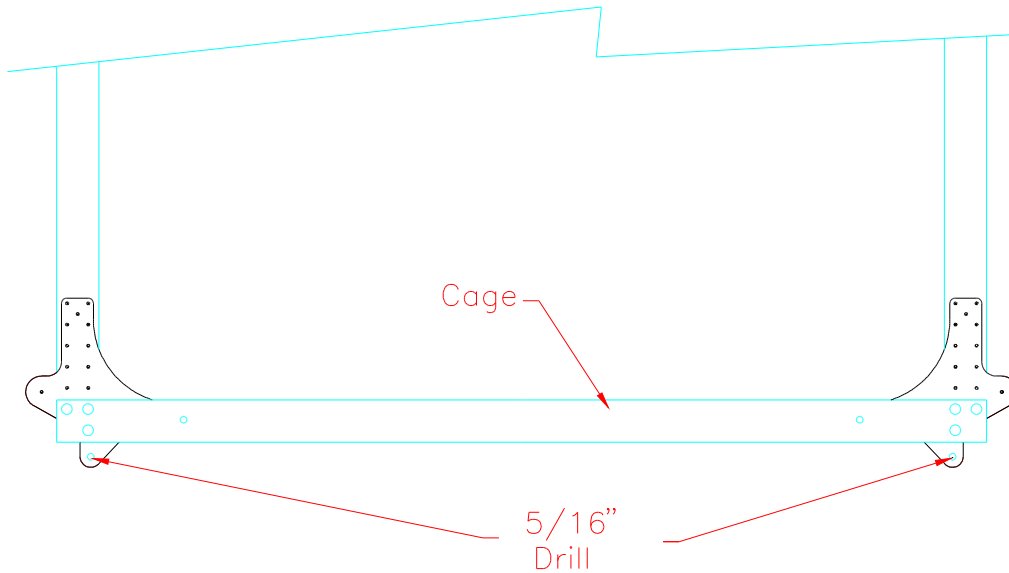

Figure 15.1.1

- 3) Drill the single hole ends of the center tubes (LG-26) out to 5/16" and fit into place as in Figure 15.1.2.

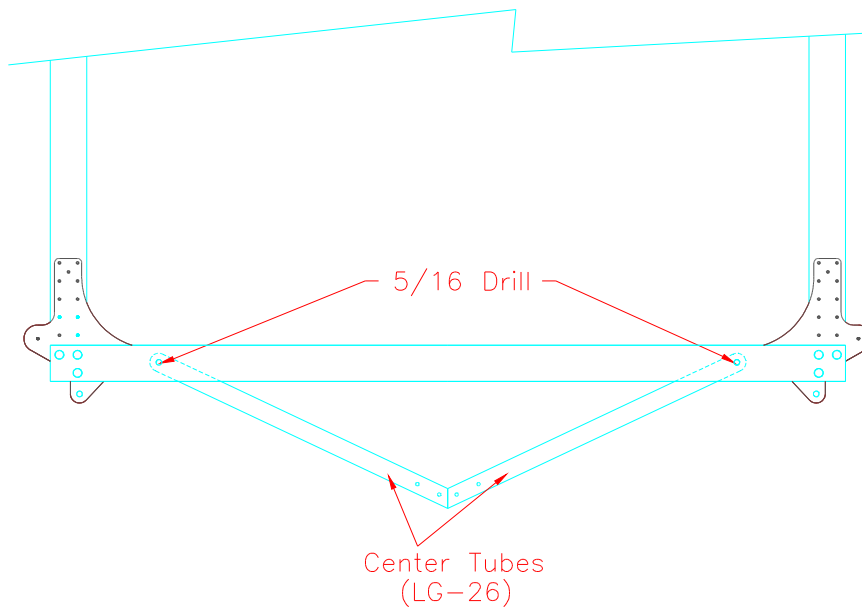

Figure 15.1.2

- 4) Bolt in place with AN5-20A bolts.
- 5) Attach two center tube gusset (LG-27-1) to the LG-26's with four AN3-15A bolts. Tighten this assembly.

6) Slip one Upper Slide Tube Doubler (LG-4) over the Upper Slide Tube (LG-5) (on the end of the LG-43 assembly) and drill hole to 3/8". Figure 5.1.3.

Figure 15.1.3

7) Measure the distance between the top hole you just drilled to the hole in the LG-43 assembly. Figure 15.1.4.

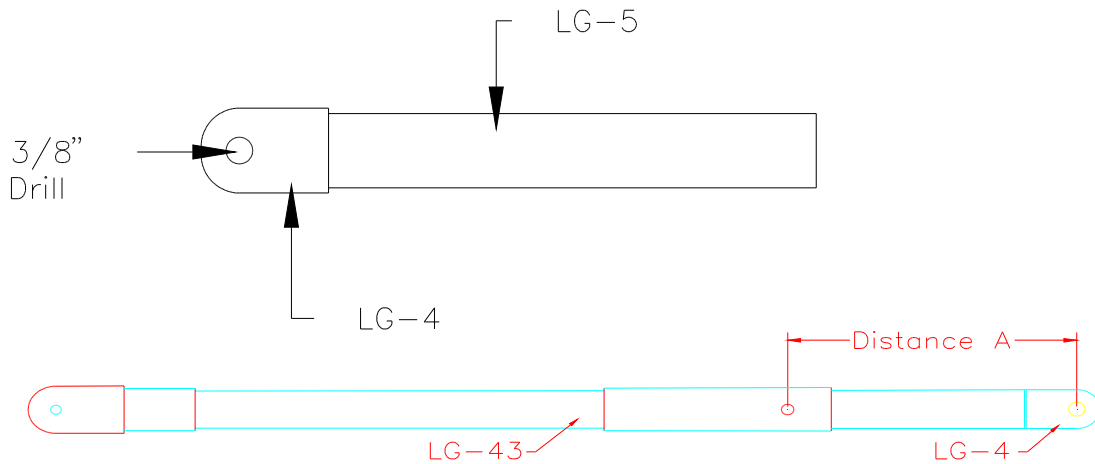

Figure 15.1.4

8) Assemble two safety cables using the measurement plus 3". Figure 15.1.5. Before swaging the one end, slip it into the Delrin Bushing (LG-6-1).

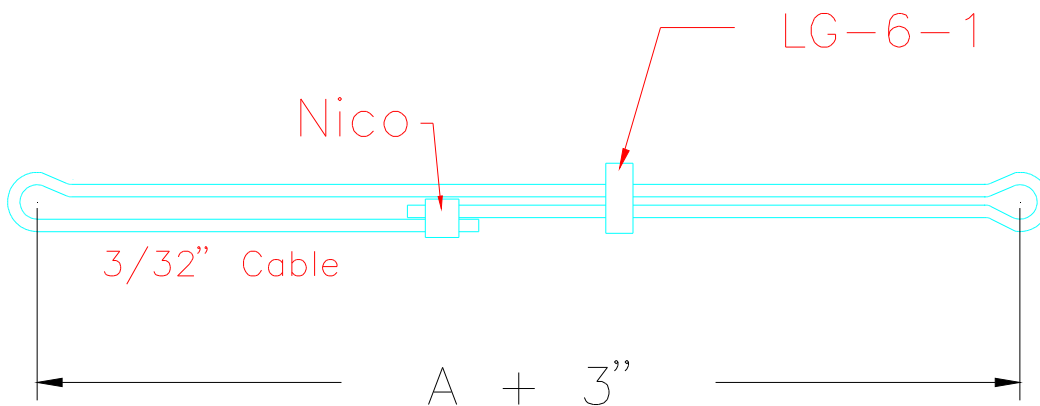

Figure 15.1.5

9) Remove the LG-4 and LG-5 assembly from the LG-43 assembly and attach it, with the safety cable, to the LG-27-1's with two AN6-35A bolts, four AN970-6 penny washers and two AN365-624 fiber nuts.

**NOTE:** Ensure the bolts go through the ends of the cable assembly. Figure 15.1.6.

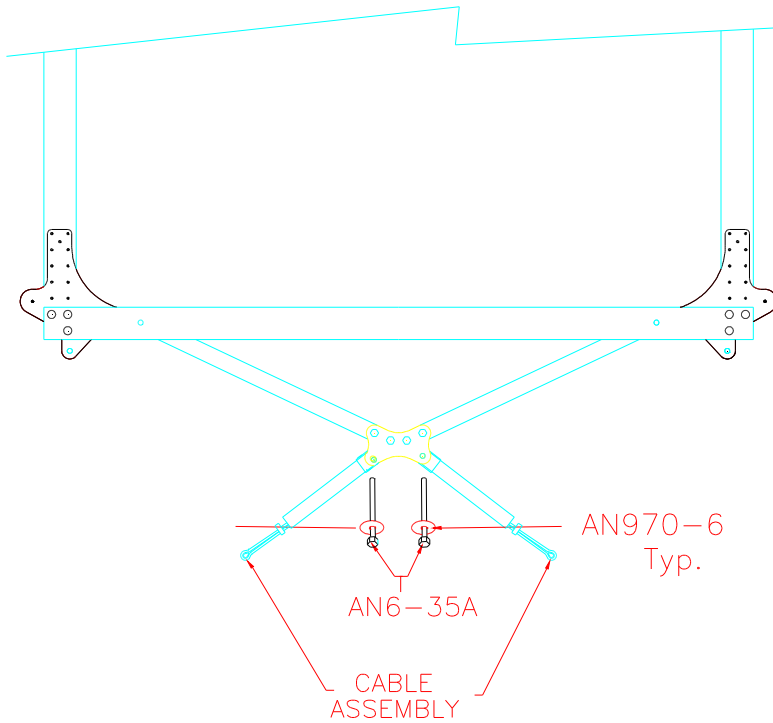

Figure 15.1.6

10) Drill the top hole in the Main Gear Leg Assembly (LG-44) to 5/16”.

11) Put a small amount of grease on each side of the top hole in the main gear leg assembly (LG-44) and attach to the cage with AN5-16A bolts. Do not over tighten. Legs must swing freely. Figure 15.1.7.

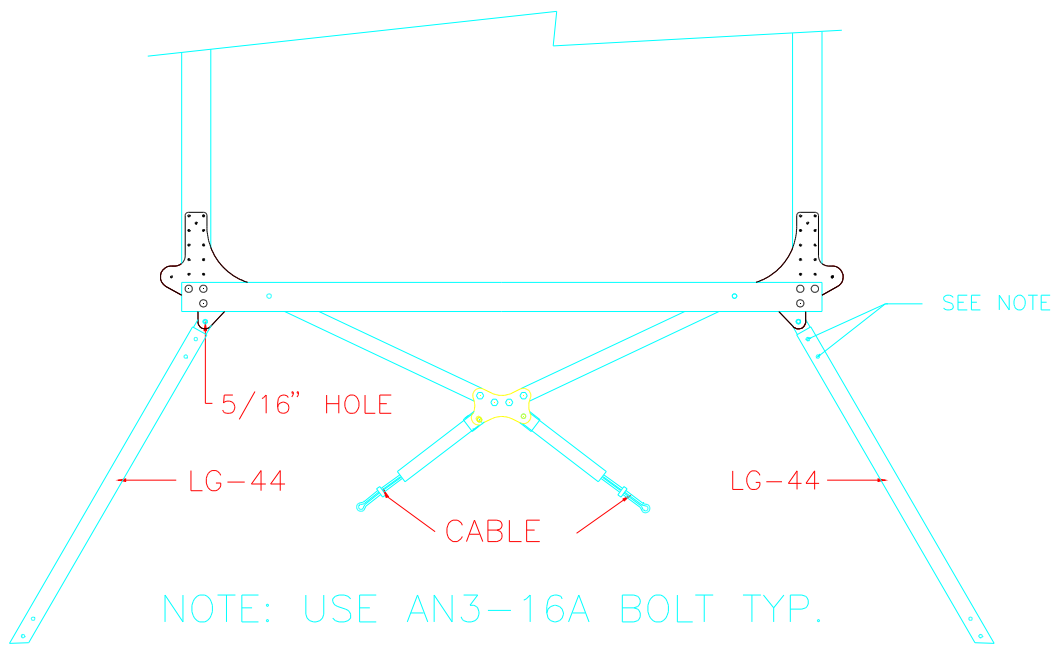

Figure 15.1.7

### 15.2 Axle Install

- 1) Assemble the wheels and hubs per instructions given with the wheel kit.
- 2) Attach brake Calipers to the axle (LG-105).

- 3) Pin with a 3/16" bolt. Cut off excess axle so that it is flush with the end of the axle block.
- 4) Place one main gear leg gusset (LG-32) on the axle block and pin. Center the LG-32 and lightly drill (#11) the other hole in the block for a locator hole. Remove the LG-32 and place a pin to hold the axle in the axle block and drill (#11) the other hole the rest of the way through the block on a drill press. Then drill both axle holes to 5/16".

### 15.3 Drag Strut Brace

- 1) Attach two LG-32, one LG-41 'Drag Brace Gusset' and one axle assembly to the bottom end of each main gear leg assembly, with AN5 bolts as shown in Figure 15.3.2. You will notice that the holes in LG-41 are off center. This is done so the sides of the LG-41 parts lie flat with the edges of the LG-32 gusset.
- 2) Put the drag struts (LG-13-1) in place and put AN4-15A bolts through fitting and strut as in Figure 15.3.1. **NOTE:** It may be necessary to trim LG-13-1 and drill a new hole at the lower location.

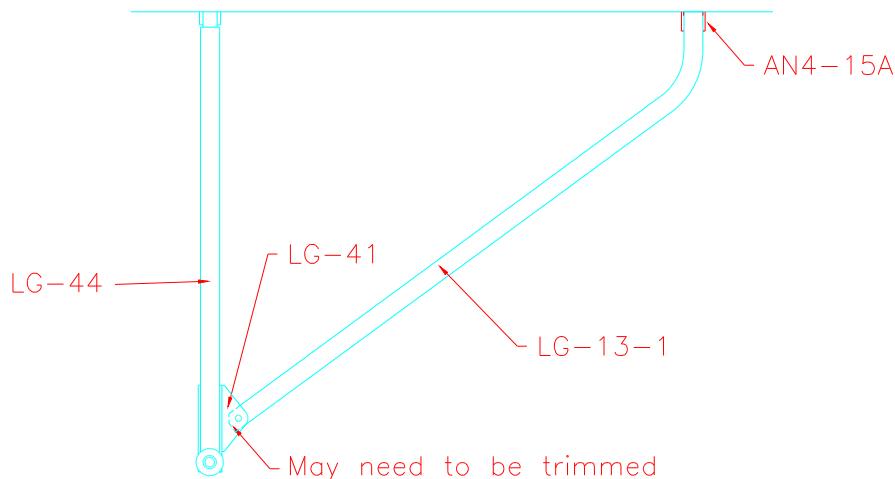

Figure 15.3.1

- 3) Center other end in the fuselage fittings and drill 1/4" through one side of the strut only. Pin with an AN4 bolt. Drill from opposite side. Lightly grease short end of LG-13-1 and install with two AN4-15A bolts. Do not over tighten.
- 4) On the lower slide tube assembly (LG-43) layout and drill four rows of four #30 holes as in Figure 15.3.2.

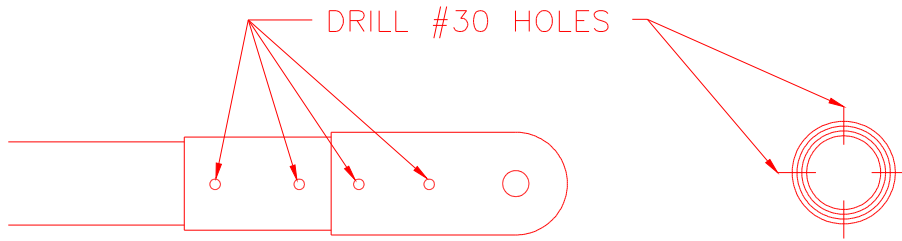

Figure 15.3.2

5) Deburr all holes and edges and rivet together with eight 1/8" rivets (RV 1410) and eight 1/8" rivets (RV 1414). Figure 15.3.3.

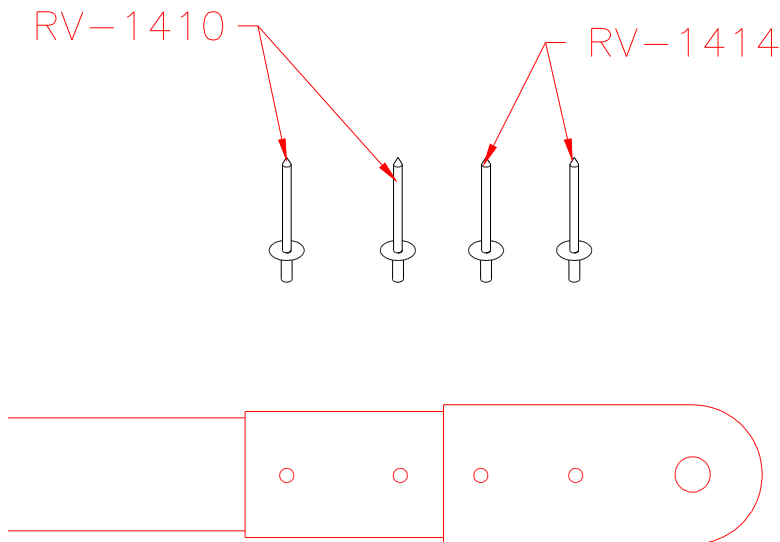

Figure 15.3.3

6) Pin the lower slide tube sleeve LG-40 onto the lower slide tube with an AN3 bolt. Drill and rivet with four rows of four 1/8" rivets (RV 1410). Figure 15.3.4.

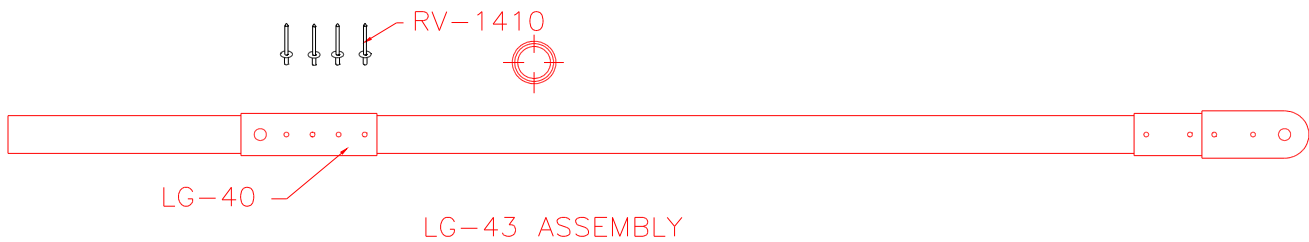

Figure 15.3.4

7) Drill both #11 holes of the lower slide tubes to 5/16" and deburr.

8) Assemble as in Figure 15.3.5, also see the assembly drawing at the beginning of this section for bolt sizes etc.

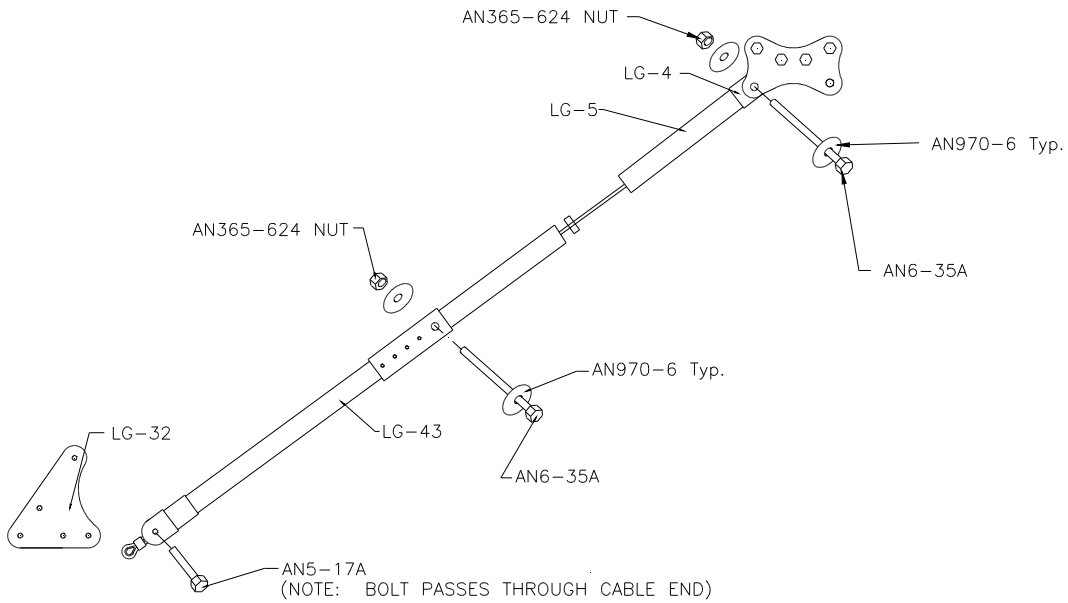

Figure 15.3.5

9) Repeat the necessary steps to complete both sides of the landing gear.

10) Install wheels and hubs.

### 15.4 Landing Gear Covering

1) Cut four of each gusset from excess .025 or .032 material to the size shown. Round the corners and drill #30 holes where indicated. Figure 15.4.1 and 15.4.2.

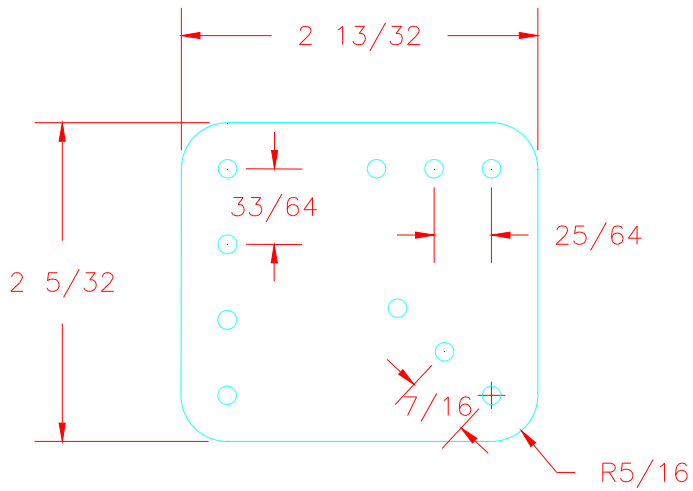

Figure 15.4.1

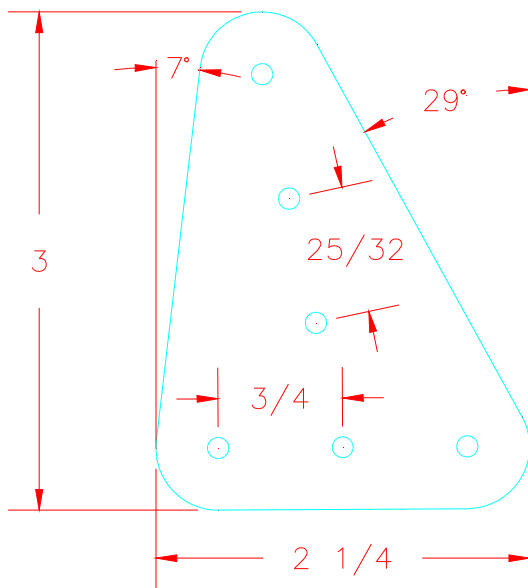

Figure 15.4.2

2) Gather two LG-47 and two LG-60 channels from the kit. Cut LG-47 to fit between the gear legs as shown in Figure 15.4.3

3) Using the gussets made in step 1 as a template, drill the holes to #30 into the gear legs and LG-47 channel. Cleco. Figure 15.4.3. Repeat for the back side.

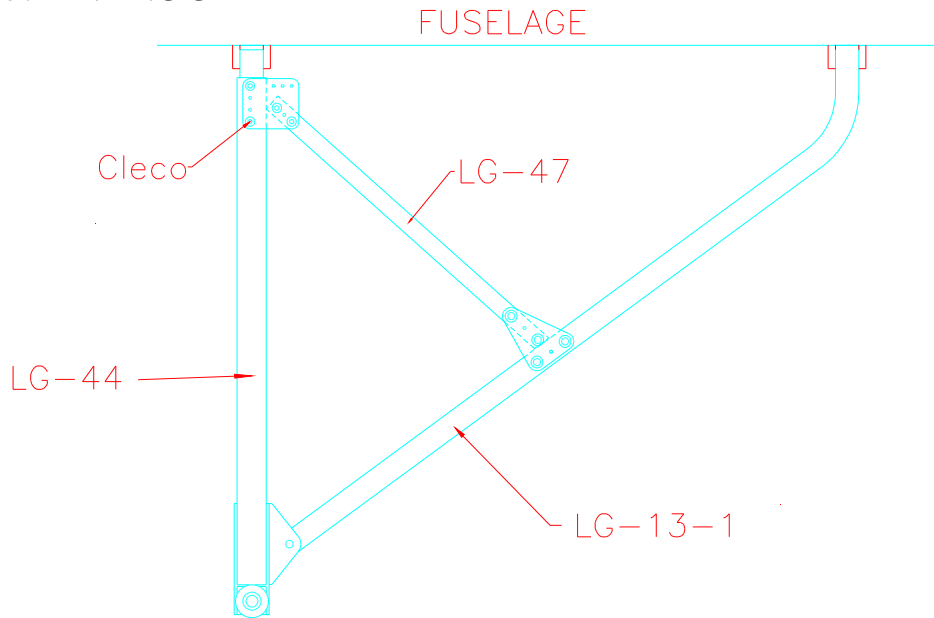

Figure 15.4.3

- 4) Cut the LG-60 channel to length if necessary with reliefs to fit between the gear legs at the top as in Figure 15.4.4.
- 5) Drill in place using the gusset holes as a template. Figure 15.4.4.

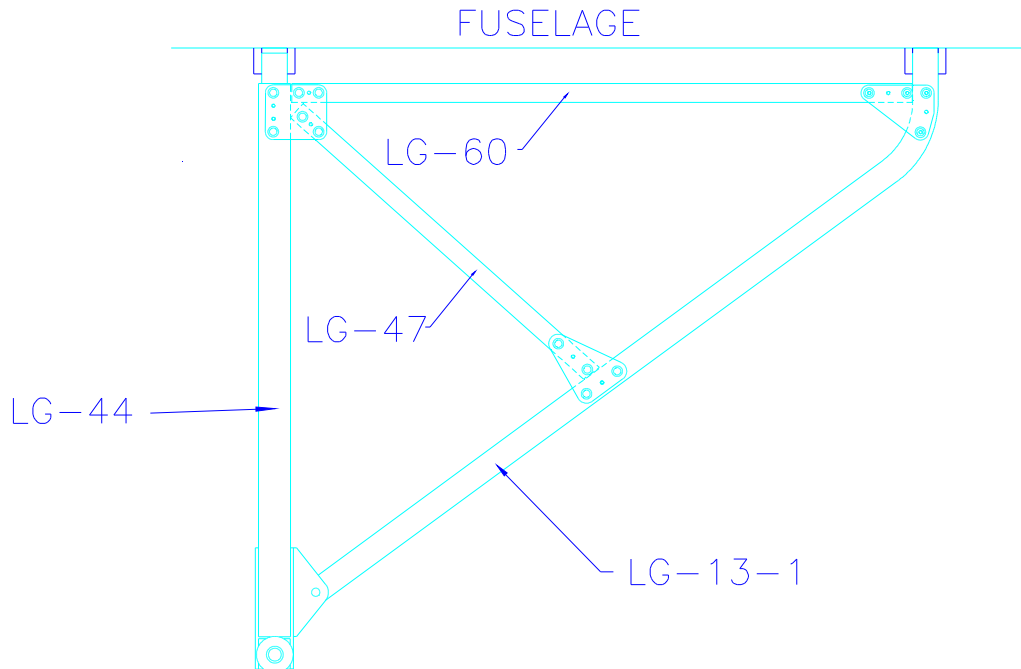

Figure 15.4.4

- 6) Deburr all parts and attach to the gear legs with 1/8" rivets (RV-1410).

- 7) The landing gear can be covered similar to other parts of the aircraft using the top channel as a support for the seam. The middle channel should be covered with reinforcing tape and have fabric rivets installed.
- 8) Follow all other procedures as per the stits covering manual.

### 15.5 Bungee Cord Installation

**Notes:** - Installing bungee cord is at least a two man job. You may wish to install bungee cord after covering and painting. Tie landing gear temporarily with rope to allow for disassembly when painting.

- 1) To install bungee you will need four 2" hose clamps, a sharp knife or razor blade, electrician's tape and a roll of strong cord, preferably waxed (flat rib stitching cord works well).
- 2) Do not cut any lengths of bungee cord supplied in the kit until you have completed the required number of wraps.
- 3) Begin by clamping one end of the cord to LG-43. Make one complete wrap around the two bolts and pull as tight as possible. Repeat for a total of 5 wraps. See Figure 15.5.1 for details.

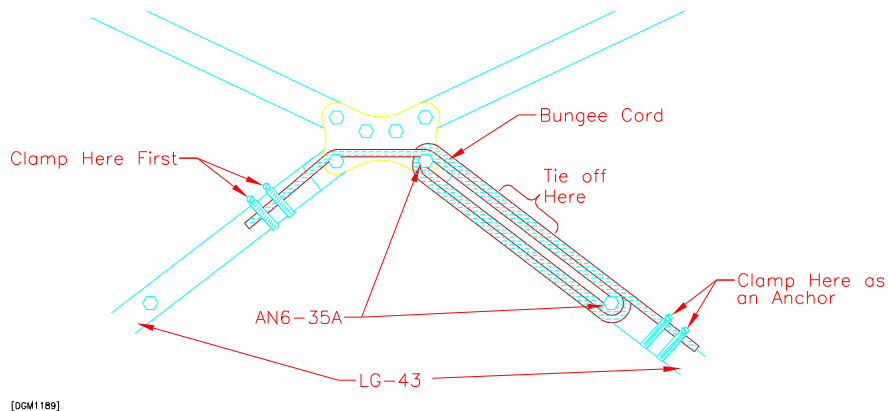

Figure 15.5.1

- 4) Clamp other end to the opposite LG-43. Tie off with cord as shown in Figure 15.5.2.

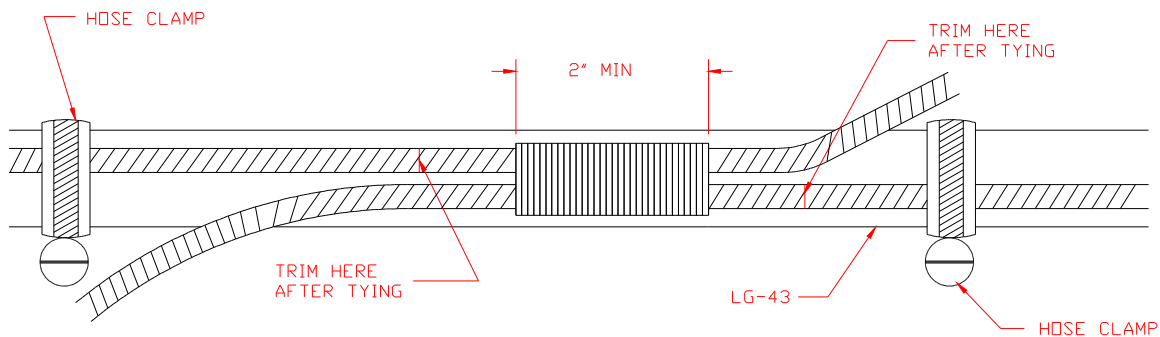

Figure 15.5.2

- 5) After tying securely, wrap ends with tape close to cord to prevent fraying. Cut bungee with razor blade approx. 1" past the tie area. Remove clamps. Repeat for the other three locations.

## 15.6 Disc Brake Installation

1) The master cylinders may be mounted according to the controls section of this manual.

Line routing and reservoir location may vary. Reservoir is shown on the top firewall, but may be placed as preferred, provided that adequate gravity flow and access for filling and inspection is maintained. Figure 15.6.1.

2) For brake line routing see Figure 15.6.1. Use high pressure plastic hose (NNR-4-035) from the master cylinder to the wheel. Clamp using Brass Elbow Fittings (269-4A) at both locations.

3) Use 3/16" T.D. Nylon Tubing (485-4) from the reservoir to a 1/4" Brass Compression Tee (264-4).

**NOTE:** The 3/16" T.D. Nylon Tubing (485-4) has to be safety wired to clamp in place at the reservoir. From the 1/4" Brass Compression Tee (264-4) run 3/16" T.D. Nylon Tubing (485-4) to Brass elbow Fittings (269-4a) at the master cylinder.

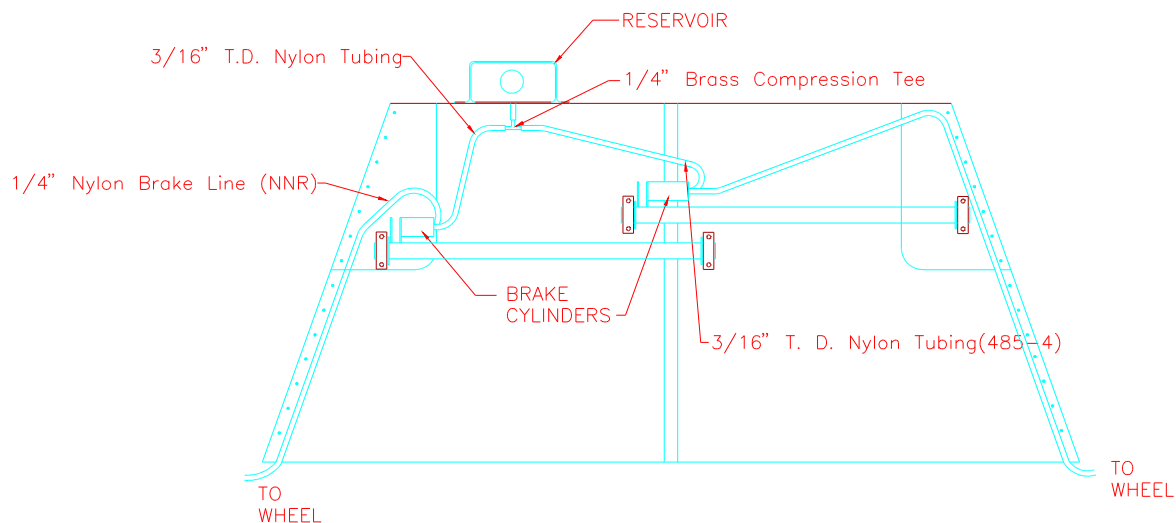

Figure 15.6.1

4) Fill reservoir with standard automotive type (**Automatic Transmission Fluid**) as brake fluid and bleed all air from the system.

**NOTE:** For safety reasons it is important to safety wire the bolts which attach the rotor to the wheel rim. This can be done as shown in Figure 15.6.2.

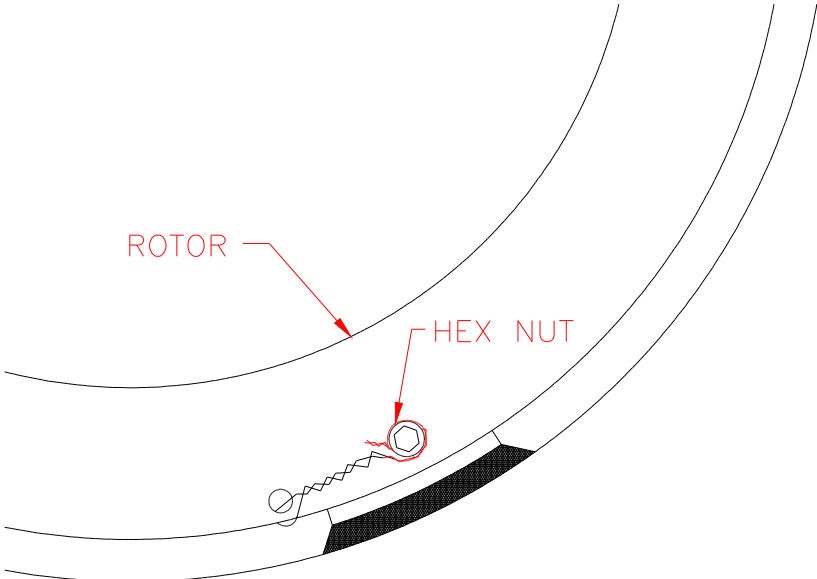

Figure 15.6.2

**NOTE:** The tied end of the safety wire should be folded around the head of the bolt to prevent snagging.