

- 34) Make a doubler from RAWST-10 to fit around the attach bracket slot. Position a FLAP0011 bearing to locate the four mounting holes. Drill the root rib and doubler 1 1/16" hole. Figure 9.4.21. Use an .063" spacer under the doubler where the root rib is depressed. Also make a

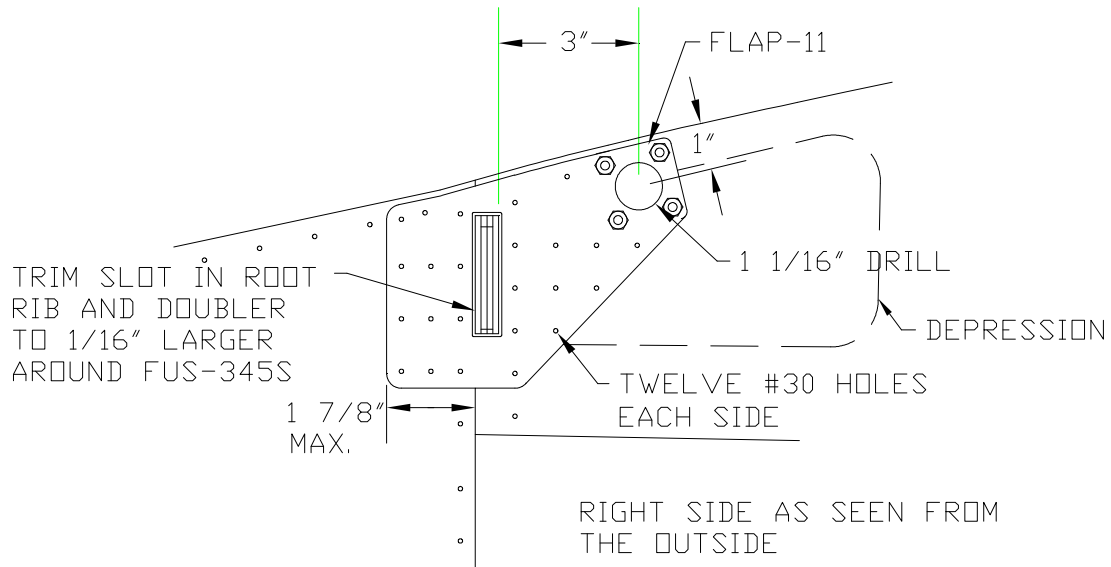

EDGM12271

Fig. 9.4.21

doubler for the front door post from RAWST-10. See Figure 9.4.22 for location and placement.

- 35) Repeat for other side.
- 36) Drill all doubler and bulkhead overlap holes to #30.
- 37) Duplicate the rivet pattern of the top of station 5 bulkhead into the new bulkhead.
- 38) From ST0040 make two clips to attach the new bulkhead legs to the root rib channel.